

Signal Conditioning Amplifier

FEATURES

- Accepts full, half, or quarter bridges; all bridge-completion gages built in, including 120/1000- and 350-ohm dummies
- Fully adjustable and regulated bridge excitation on each channel; up to 12 VDC by front-panel control
- Continuously variable amplifier gain up to 2100 by front-panel control
- Separate bridge-power switch
- Output 10 VDC at 100 mA, short-circuit-proof and current limiting standard
- LED null indicators provided on each channel to indicate amplifier and bridge-balance condition
- High stability with temperature and time
- Frequency response up to 50 kHz
- Direct channel-by-channel display of data, with optional peak hold/retention capability

DESCRIPTION

The demands of today's measurement applications are more exacting than ever before. An instrumentation system must provide durability and versatility, reliability with ease of operation, and economy with no sacrifice of accuracy.

The 2100 System was engineered with all of these requirements in mind, and to provide a durable, multi-channel signal conditioner/amplifier system capable of performing equally well in a wide variety of test applications and environments. And the 2100 System has proven itself through applications ranging from measurements on the ocean floor to testing of the space shuttle.

The 2100 System accepts low-level signals, and conditions and amplifies them into high-level outputs suitable for multiple-channel simultaneous dynamic recording. The 2100 System is compatible with strip charts, magnetic tape and X-Y recorders.

Strain gage, load/pressure transducer and nickel temperature sensor inputs can be handled by the 2100 System without any rewiring.

An important design objective achieved is miniaturization of the system while maintaining adequate spacing around the front-panel controls. All operational controls are located on the front panel for maximum setup efficiency. Frequently used controls are finger-operated, while initial setup adjustments are made through the front panel with a screwdriver.

Continuously variable amplifier gain is achieved via a locking ten-turn concentric-dial counting knob, which permits resetting to a predetermined value for repeating routine tests.

A combination of integrated circuits and discrete components assures maximum performance and ease of service at the lowest possible price.

CONFIGURATION

A 2100 System consists of:

- One to five modules—Model 2120B Strain Gage Conditioner/Amplifier (two channels/module)
- One Model 2110B Power Supply
- One Model 2150 Rack Adapter



OR

- One or two modules—Model 2120B Strain Gage Conditioner/Amplifier (two channels/module)
- One Model 2110B Power Supply
- One Model 2160B Portable Four-Channel Enclosure

ADDITIONAL DETAILS

- A **separate bridge power switch** removes bridge excitation, enabling the operator to detect unwanted signals due to electrical interference and/or noise, thermocouple effects, and shifts of the instrument zero during a long-term test. This feature is an absolute must for dynamic testing, and for validating test results.
- An **adjustable bridge excitation control** on each channel permits excitation to be set as specified by the strain gage or transducer manufacturer. It also allows for any special consideration which may be dictated by the test material; for example, the poor thermal conductivity normally associated with plastics.
- In addition to adjustable bridge excitation, each channel has its own **regulator circuit**. This prevents interaction of adjacent channels during setup or operation.
- Each channel has a **continuously variable gain control**. In combination with recommended excitation, the independent gain control can provide a large output signal so that small signals can be resolved without overpowering the strain gage or transducer.
- An **LED display for each channel** gives positive indication of amplifier and resistive balance. This capability accelerates setup and verifies tension/compression loading.
- Easily read **reference marks** on the setup meter indicate acceptable line voltage and proper operation of internal power supplies.
- A switch contained in the Model 2110B Power Supply allows adjustment when the **line voltage** is too high or too low.
- The 2100 System provides **true quarter-bridge, three-leadwire capability**, including internal dummies and sufficient plug connections for remote shunt calibration.
- A convenient network in the Model 2120B Strain Gage Conditioner/Amplifier **allows the operator to change the factory-supplied shunt values**, as well as shunt any arm of the bridge, as required.

Signal Conditioning Amplifier

MODEL 2120B STRAIN GAGE CONDITIONER AMPLIFIER

A two-channel plug-in amplifier module that includes bridge completion, bridge balance, amplifier balance, bridge excitation regulator, and shunt calibration.

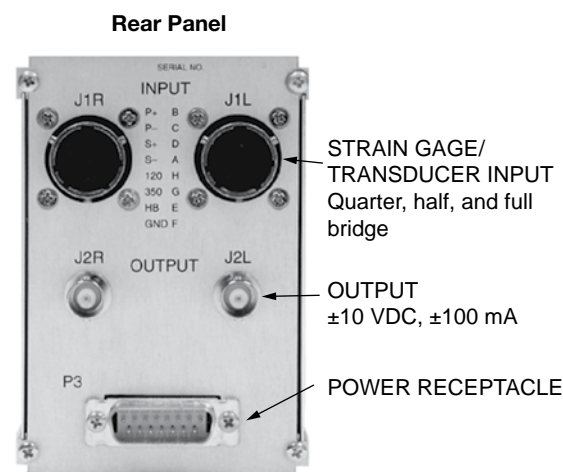
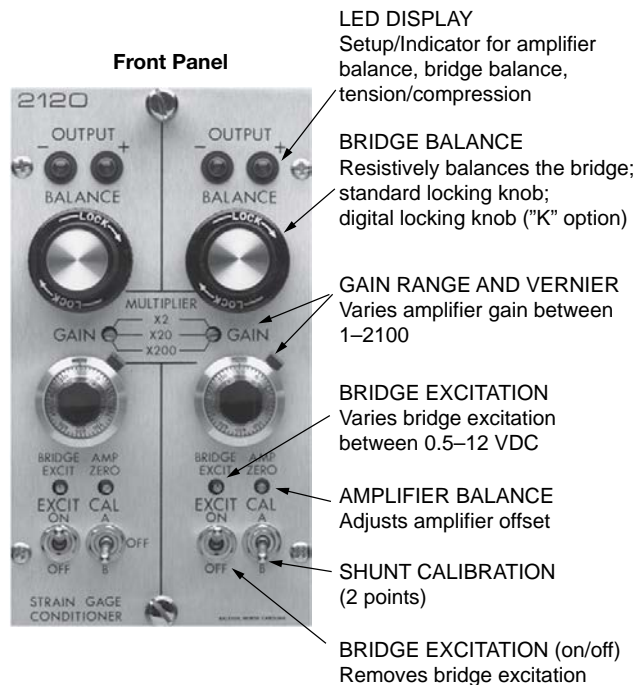

SPECIAL PORTION OF PRINTED CIRCUIT BOARD FOR SHUNT CALIBRATION RESISTORS AND JUMPERS

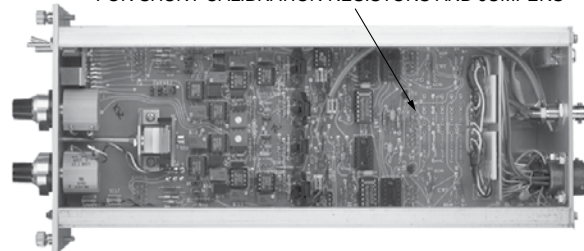

SPECIFICATIONS

All specifications in this datasheet are nominal or typical at +23°C unless noted. Performance may be degraded in the presence of high-level electromagnetic fields.

Inputs

Quarter (120Ω/1000Ω and 350Ω), half and full bridge (50-1000Ω). Quarter-bridge dummy gages provided.

Bridge Excitation

0.5 to 12 VDC (adjustable for each channel) with 120Ω full-bridge load.

Short-circuit current: <40 mA

Ripple, noise, and 10% line change: ±2 mV max.

Load regulation: ±0.2% no-load to 120Ω load (10% line change)

Bridge Balance

±2000 με (quarter, half, or 350Ω full bridge), range can be changed by internal jumper to ±4000 με or ±6000 με

Calibration

Two-position (center off) toggle switch

Standard factory-installed resistors (±0.1%) simulate ±1000 με at GF=2

Amp Gain

1 to 2100 continuously adjustable ±1%.

Bandpass

DC to 5 kHz (min): -0.5 dB (-5%)

DC to 15 kHz: -3 dB

Can be extended by internal jumper to:

DC to 17 kHz: -0.5 dB

DC to 50 kHz: -3 dB

Amp Input

Temperature coefficient of zero

±1 μV/°C RTI*, ±210 μV/°C RTO**

-10°C to +60°C (after 30 minute warm-up)

Noise RTI: (350Ω source impedance)

1 μV p-p at 0.1 Hz to 10 Hz

2 μV p-p at 0.1 Hz to 100 Hz

2 μVRMS at 0.1 Hz to 50 kHz

*Referred to input

**Referred to output

Signal Conditioning Amplifier

Noise RTO

50 μ V p-p at 0.1 Hz to 10 Hz
80 μ V p-p at 0.1 Hz to 100 Hz
100 μ VRMS at 0.1Hz to 15 kHz
200 μ VRMS at 0.1Hz to 50 kHz

Input Impedance

>100 M Ω (balance limit resistor disconnected)

Common-Mode Rejection

(DC to 60 Hz)

Gain Multiplier	CMR (dB)
X2	67
X20	87
X200	100

Source Current

\pm 10 nA typical; \pm 40 nA max.

Output

\pm 10V (min) at \pm 100 mA
Current limit: 140 mA

Size

5.25 H x 2.94 W x 10.97 D in (133 x 75 x 279 mm)

Weight

2.2 lb (1.0 kg)

MODEL 2110B POWER SUPPLY

A plug-in module capable of powering up to ten channels (five Model 2120B modules) at a maximum rated voltage or current.

Provides initial bridge and amplifier voltages. All supplies are current-limited against amplifier malfunction.



BRIDGE-VOLTS METER
Used to set up/monitor bridge excitation, also line and power supply levels

CHANNEL SELECTOR
AC monitors ac line input. DC monitors the power supplies. Positions 1-10 select and display bridge excitation for each channel

PILOT LAMP
Indicates main power

POWER SWITCH
Main power on-off

EXTERNAL METER
Used with an external digital voltmeter to precisely adjust bridge excitation

SPECIFICATIONS

Outputs

\pm 15V at 1.2A and +17.5V at 1.1A; all regulators current-limited against overload

Input

107, 115, 214, 230 VAC \pm 10% 50/60 Hz (selected internally)

Power: 40W typical, 100W max.

Meter

0 to 12 VDC (with switch) to read bridge excitation. Also AC input and DC output go/no-go monitor

Size

5.25 H x 2.44 W x 12.34 D in (133 x 62 x 313 mm)

Weight

6.7 lb (3.1 kg)

MODEL 2150 RACK ADAPTER

A prewired rack adapter which accepts one Model 2110B and up to five Model 2120B Strain Gage Conditioner Amplifiers. It has its own fuse and power cord and can be housed in any standard 19-in (483-mm) electronic equipment rack.

Power

2-ft (0.6-m) 3-wire line cord; 10-ft (3-m) extension available

Fuse: 1A size 3 AG (32 x 6.5 dia. mm)

Receptacle to accept line cord from adjacent 2150 Rack Adapter

Size

5.25 H x 19 W x 14.17 D in (133 x 483 x 360 mm)

Weight

6.6 lb (3.0 kg)



MODEL 2150 FRONT

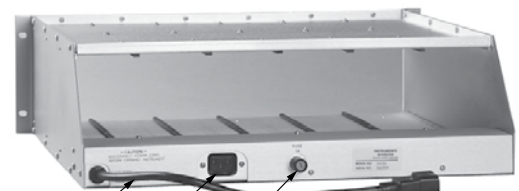

MODEL 2150 REAR
LINE CORD
AUXILIARY RECEPTACLE
FUSE

Signal Conditioning Amplifier

MODEL 2160B PORTABLE FOUR-CHANNEL ENCLOSURE

Model 2160: A prewired, fused enclosure which houses up to three (3) modules. A carrying handle ensures maximum portability. An additional snap-down bail support on the bottom can be used to elevate the 2160 for excellent work efficiency during bench-top operation. The Model 2160 would be substituted for the Model 2150 when two or four channels and maximum portability are required.

SPECIFICATIONS

Size

5.55 H x 8.75 W x 13.80 D in (141 x 222 x 350 mm)

Weight

5.2 lb (2.4 kg)



Disclaimer

ALL PRODUCTS, PRODUCT SPECIFICATIONS AND DATA ARE SUBJECT TO CHANGE WITHOUT NOTICE.

Vishay Precision Group, Inc., its affiliates, agents, and employees, and all persons acting on its or their behalf (collectively, "Vishay Precision Group"), disclaim any and all liability for any errors, inaccuracies or incompleteness contained herein or in any other disclosure relating to any product.

The product specifications do not expand or otherwise modify Vishay Precision Group's terms and conditions of purchase, including but not limited to, the warranty expressed therein.

Vishay Precision Group makes no warranty, representation or guarantee other than as set forth in the terms and conditions of purchase. **To the maximum extent permitted by applicable law, Vishay Precision Group disclaims (i) any and all liability arising out of the application or use of any product, (ii) any and all liability, including without limitation special, consequential or incidental damages, and (iii) any and all implied warranties, including warranties of fitness for particular purpose, non-infringement and merchantability.**

Information provided in datasheets and/or specifications may vary from actual results in different applications and performance may vary over time. Statements regarding the suitability of products for certain types of applications are based on Vishay Precision Group's knowledge of typical requirements that are often placed on Vishay Precision Group products. It is the customer's responsibility to validate that a particular product with the properties described in the product specification is suitable for use in a particular application.

No license, express, implied, or otherwise, to any intellectual property rights is granted by this document, or by any conduct of Vishay Precision Group.

The products shown herein are not designed for use in life-saving or life-sustaining applications unless otherwise expressly indicated. Customers using or selling Vishay Precision Group products not expressly indicated for use in such applications do so entirely at their own risk and agree to fully indemnify Vishay Precision Group for any damages arising or resulting from such use or sale. Please contact authorized Vishay Precision Group personnel to obtain written terms and conditions regarding products designed for such applications.

Product names and markings noted herein may be trademarks of their respective owners.