

Series 350

General Purpose DC Gaging LVDTs

The Series 350 DC Gaging Transducers are an integrated package consisting of a spring loaded spindle, precision linear variable differential transformer, a solid state oscillator, and a phasesensitive demodulator. The transducer is designed for excellent linearity, infinite resolution, and high sensitivity. Input and output circuits are electrically isolated from each other and from the coil assembly housing, making them usable directly in floating or ground return systems. DC indicators, recorders, and control systems can usually be driven directly by the large DC output. The spindle, when displaced axially within the coil assembly, produces a voltage change in the output directly proportional to the displacement.



KEY FEATURES

Ranges from $\pm 0.05"$ to $\pm 3.0"$	6 to 28 VDC Excitation
Non-linearity < 0.5%	High Sensitivity

SPECIFICATIONS

MODEL NUMBER	0350-0000	0350-0010	0351-0000	0351-0006	0352-0000	0353-0000	0354-0000	0355-0000	0356-0000
WORKING RANGE \pm Inches (mm)	0.050 (1.27)	0.050 (1.27)	0.10 (2.54)	0.10 (2.54)	0.25 (6.35)	0.50 (12.7)	1.00 (25.4)	2.00 (50.8)	3.00 (76.2)
MECH. TRAVEL, Inches (mm)	0.16 (4.06)	0.14 (3.56)	0.31 (7.87)	0.31 (7.87)	0.75 (19.1)	1.25 (31.8)	2.25 (57.2)	4.25 (108)	6.25 (159)
INPUT, VDC	6.0 Min. to 28 Max.								
NOMINAL F.S. OUTPUT \pm VDC (tested with load impedance simulating open circuit)									
@ 6 VOLT INPUT	1.2	1.2	2.1	2.0	1.6	3.0	4.3	4.0	3.1
@ 15 VOLT INPUT	3.0	3.0	5.4	5.8	4.2	7.5	10.8	10.0	7.8
@ 24 VOLT INPUT	5.0	5.0	9.0	9.4	7.0	12.5	18.0	16.0	13.0
@ 28 VOLT INPUT	5.6	5.8	10.1	10.4	7.9	14.0	20.3	18.7	14.6
INPUT CURRENT	6.3 mA @ 6 Volt input to 48 mA @ 28 Volt input								
LINEARITY % FULL SCALE OVER TOTAL WORKING RANGE ± 0.50									
INTERNAL CARRIER FREQ., Hz NOM. GREATER THAN:	13000	13000	12000	14000	3600	3400	3200	1500	1400
% RIPPLE (RMS) NOM.	0.7	0.7	0.7	0.7	0.8	0.8	0.8	1.0	1.0
OUTPUT IMPEDANCE, Ohms	2500	2500	3500	3500	5200	5500	5600	5500	5600
TEMPERATURE RANGE	-65°F to +200°F (-54°C to +93°C)								
RESOLUTION	Infinite								

BLOCK DIAGRAM

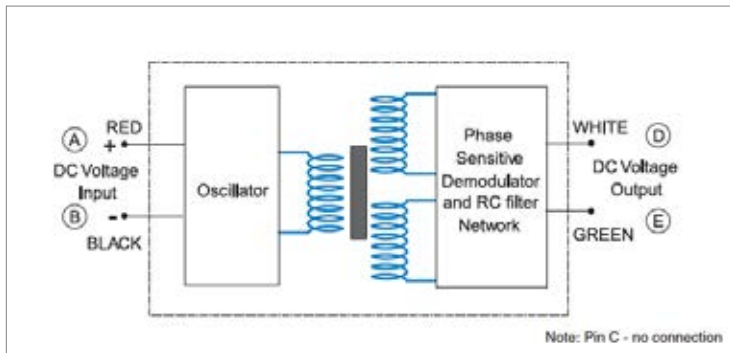

Notes:

1. Polarity of excitation must be observed for proper function. Reversal will not damage the unit.
2. Load Impedance of 50 KOHms minimum required for proper operation.
3. Output polarity will be positive on one side of null, negative on the other side of null.
4. Transducers are calibrated at 24 VDC.
5. White lead is more positive with respect to the Green lead when the core is moved toward the lead end.

SPECIFICATIONS - MECHANICAL

MODEL	UNITS	0350-0000	0350-0010	0351-0000	0351-0006	0352-0000	0353-0000	0354-0000	0355-0000	0356-0000
FIGURE #		1	3	1	3	2	2	2	2	2
TOTAL LENGTH A	Inches (mm)	3.01 (76.5)	2.63 (66.8)	3.52 (89.4)	3.74 (95.0)	9.89 (251)	10.89 (277)	15.31 (389)	25.43 (646)	35.02 (890)
SHAFT EXTENSION B	Inches (mm)	0.41 (10.4)	0.39 (9.91)	0.56 (14.2)	0.56 (14.2)	1.42 (36.1)	1.42 (36.1)	2.42 (61.5)	4.75 (121)	6.75 (172)
TIP FORCE MAX	Grams	57	57	170	85	312	425	482	1276	1361
WEIGHT	Grams	200	104	207	125	239	275	372	625	845

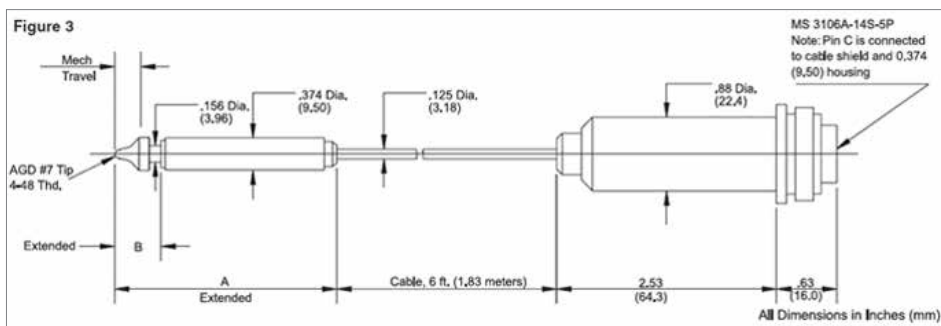
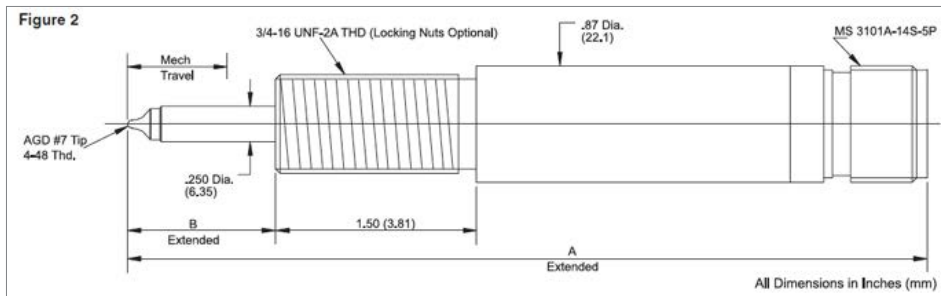
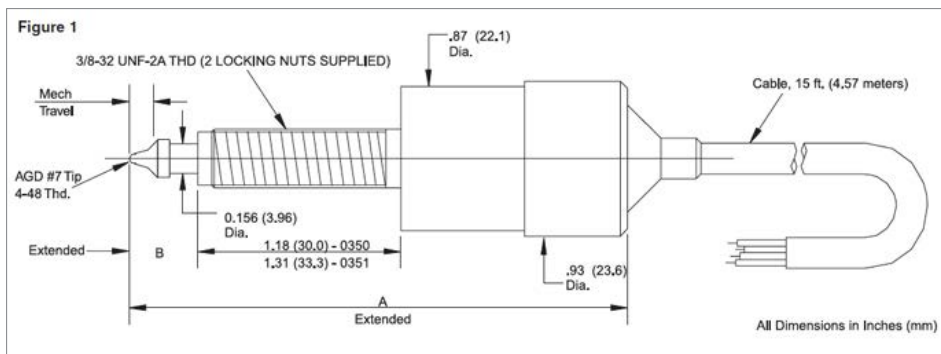

ACCESSORIES & OPTIONS

PART NUMBER	DESCRIPTION
C003-0007	Mating Connector Assembly: Connector MS3106A-14S-5S (mates with MS3101A-14S-5P), Cable clamp, and Strain Relief
C000-0022	Cable Assembly: 15 feet of 4 conductor, 22 AWG vinyl cable terminated with C003-0007. (Note: Operating temperature for cable is -22°F to +176°F); Color Code: A – Red, B – Black, D – White, E – Green
C003-0027	Mating Connector Assembly: Connector MS3101A-14S-5S (mates with MS3106A-14S-5P), Cable clamp, and Strain Relief
C000-0026	Cable Assembly: 15 feet of 4 conductor, 22 AWG vinyl cable terminated with C003-0027. (Note: Operating temperature for cable is -22°F to +176°F); Color Code: A – Red, B – Black, D – White, E – Green
G000-0000	Replacement AGD #7 Gaging Tip. (Included with transducer)
N001-0025	3/4 X 16 UNF-1B Hex Jam Nut

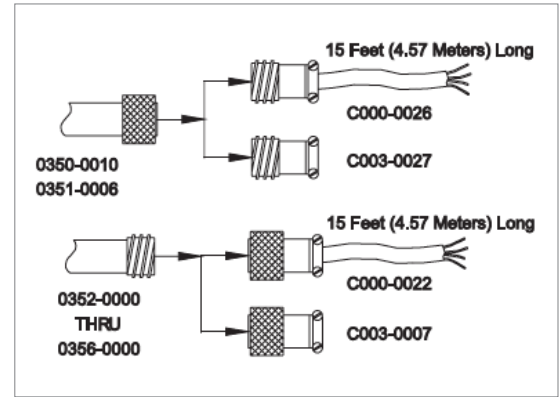

SALES OPTIONS

OPTION #	DESCRIPTION
X0027:	Reverse spring; spring will be in retracted position Applies to Models 0350-0000, 0350-0010, 0351-0000, and 0351-0006
X0031:	Special length interconnecting cable (10 ft. Max.) Applies to Models 0350-0010 and 0351-0006
X0038:	Alternate spring selection (not available for Models 0355-0000 and 0356-0000). See following page for spring model numbers and corresponding tip force
The following options apply only to Models 0352-0000 through 0356-0000:	
X0013:	Vented housing and LVDT for high pressure applications
X0014:	Terminate in 7" leads instead of connector
X0028:	Reverse spring; spring will be in retracted position
X0029:	Air Purge port for maintaining positive air pressure in the unit
X0030:	Non-rotating shaft

AIR-ACTUATED VERSIONS

In certain gaging applications, such as part inspection systems, it is desirable to have the shaft fully retracted and actuated by the application of positive air pressure.

There are two models available with this option, Models 0350-0012 and 0351-0012. These units are physically identical to the standard -0000 versions, except the spring is reversed to keep the shaft retracted, and a 3/16" stainless steel air inlet is added at the cable end. Filtered shop air can be used to actuate the shaft at user defined intervals.

DIMENSIONAL DRAWING

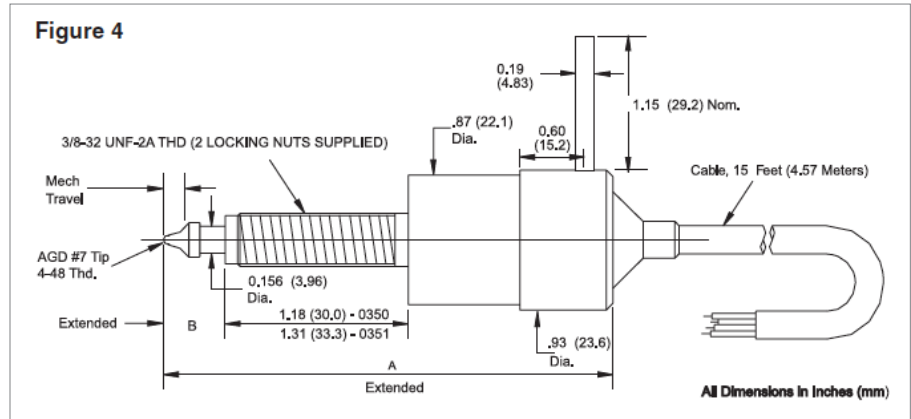

NON-LINEARITY	UNITS	0350-0012	0351-0012
STROKE	±Inches (mm)	0.05 (1.27)	0.10 (2.54)
TOTAL LENGTH A	±Inches (mm)	3.01 (76.5)	3.52 (89.4)
SHAFT EXTENSION B	±Inches (mm)	0.41 (10.4)	0.56 (14.2)
MIN. AIR PRESSURE FOR COMPLETE ACTUATION	PS.I.	10	20

ALTERNATE SPRINGS TO BE USED IN OPTION X0038

The standard springs are designated by an asterisk*. The tip force is given for operation within the linear region of the transducer at full extension (TF-), full compression (TF+), and the null position (TF₀). The tip forces were determined while the transducer was in the vertical position, pointing down. To determine the tip force when the unit is in a horizontal position, simply subtract the shaft

assembly weight from the tip force. To determine the tip force when the unit is vertical, and pointing up, subtract twice the shaft assembly weight. The weight of the shaft assembly includes both the weight of the shaft and the return spring(s). Both the tip forces and the weight of the shaft assembly are given in grams. To convert this value to ounces, divide by 28.38.

MODEL	SHAFT RETURN SPRING		TIP FORCE VERSUS POSITION (gm)			SHAFT ASSEMBLY (gm)
	SPRING	QTY	TF -	TF ₀	TF +	
0350-0000	S006-0001	1	8.5	9.9	11.5	3
	S006-0000*		33	41	53	3
	S006-0023		57.5	79	96.5	3.1
	S006-0022		130	204	287	3.2
	S006-0021		350	462	616	3.1
0350-0010	S006-0001	1	7.5	9.2	11	2.2
	S006-0000*		35	42.5	54	2.2
	S006-0023		64	82.5	101	2.3
	S006-0022		133	220	300	2.4
	S006-0021		378	510	658	2.3
0351-0000	S006-0001	1	9.5	11.5	13.5	3.8
	S006-0000*		37.5	45	57	3.8
	S006-0023		63.1	87	109	3.8
	S006-0022		161	240	332	4
	S006-0021		406	532	714	3.9
0351-0006	S006-0001	1	9	11.5	13.5	3.8
	S006-0000*		31	45	53	3.9
	S006-0023		50	70	89	3.9
	S006-0022		131	193	275	4.1
	S006-0021		339	440	500	4
0352-0000	S006-0020	1	61.5	96.7	114.3	25.8
	S006-0012		114.3	161	205.1	26
	S006-0004*		205	310	408.5	26
	S006-0008		448	588	728	26
0353-0000	S006-0020	1	96.7	169.9	222.7	26.5
	S006-0012		143.6	210.9	392.6	26.5
	S006-0004*		190.5	427.8	596.5	26.5
	S006-0008		495.2	764.7	1060.7	26.5
0354-0000	S006-0020	2	51.5	108.6	157.1	42.5
	S006-0012		93.5	140	224.5	42.5
	S006-0004*		112.5	182	448.6	42.5
	S006-0008		235.2	562.8	974.4	42.6
0355-0000	S006-0008*	3	357.5	714.9	1265.8	72.7
0356-0000	S006-0008*	5	427.8	688.5	1295.1	115.4

Note: *Standard Spring