

Series 310-320

Long Stroke AC Gaging LVDTs

The Series 310-320 Long Stroke AC Gaging Transducers consist of a precision AC LVDT, a rugged stainless steel outer housing, and a spring actuated, stainless steel shaft. Consistent with the high performance normally found in Trans-Tek precision AC LVDTs, these transducers exhibit excellent non-linearity and extremely low temperature coefficients. Available in full stroke displacements of 0.5 to 20 inches, the transducers are ideal for use in single or multi-point gaging systems, thickness measurements, machine control, or any other applications requiring a precision, spring actuated linear displacement measurement.



KEY FEATURES

Ranges from $\pm 0.25"$ to $\pm 10.0"$	Stainless Steel Construction
Non-linearity $\leq 0.25\%$	Reversible Spring Option

SPECIFICATIONS

MODEL	LINEAR RANGE \pm Inches (mm)	MAX USABLE RANGE \pm Inches (mm)	MAX TIP FORCE Ounces	TOTAL LENGTH A Inches (mm)	SHAFT LENGTH B Inches (mm)	INPUT IMPEDANCE Ohms	DC INPUT RESISTANCE Ohms	OUTPUT IMPEDANCE Ohms	PHASE ANGLE Degrees
0315-0000	0.25 (6.35)	0.50 (12.7)	20	8.96 (228)	1.47 (37.3)	205	22	265	13
0316-0000	0.50 (12.7)	0.87 (22.1)	27	11.05 (281)	2.32 (58.9)	235	31	310	17
0317-0000	1.00 (25.4)	1.37 (34.8)	27	15.26 (388)	3.42 (86.9)	195	36	205	19
0318-0000	2.00 (50.8)	2.37 (60.2)	36	22.51 (572)	5.56 (141)	200	46	255	22
0319-0000	3.00 (76.2)	3.62 (91.9)	45	31.13 (791)	8.13 (207)	225	57	285	25
0320-0000	5.00 (127)	5.80 (147)	42	47.31 (1202)	12.85 (326)	360	89	460	31
0321-0000	7.50 (191)	8.25 (210)	41	68.23 (1733)	18.38 (467)	235	55	235	30
0322-0000	10.00 (254)	10.75 (273)	40	86.93 (2208)	23.88 (607)	330	72	285	31

DIMENSIONAL DIAGRAM

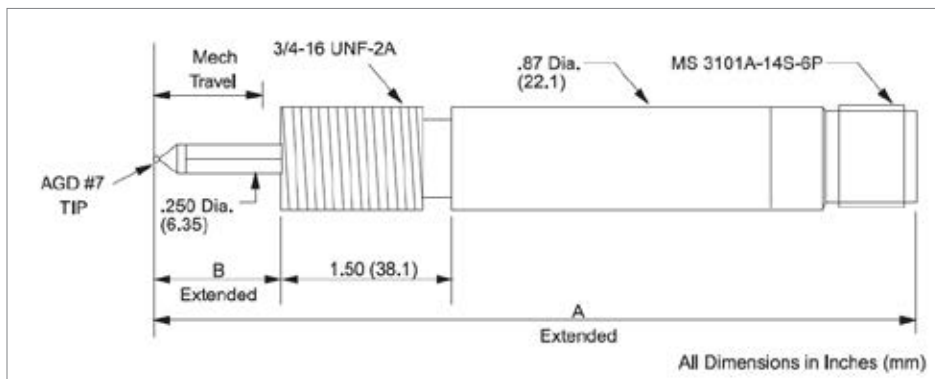

TRANSDUCER SPECIFICATIONS

NON-LINEARITY	$\leq \pm 0.25\%$ FS (Best Fit Straight Line)
REFERENCE FREQUENCY	7.0 KHz
SENSITIVITY	0.50 V/V $\pm 10\%$ at FULL SCALE
INPUT VOLTAGE	20 VRMS, Max.
NULL VOLTAGE	< 1.0% Excitation Voltage
TEMPERATURE COEFFICIENT	< $\pm 0.001\%$ FS/ $^{\circ}$ F Zero, < $\pm 0.01\%$ Reading/ $^{\circ}$ F Span
TEMPERATURE RANGE	-67 $^{\circ}$ F to +220 $^{\circ}$ F (-55 $^{\circ}$ C to +104 $^{\circ}$ C) Operating -67 $^{\circ}$ F to +275 $^{\circ}$ F (-55 $^{\circ}$ C to +135 $^{\circ}$ C) Storage
MATERIALS	Stainless Steel Housing and Shaft; Aluminum

SCHEMATIC

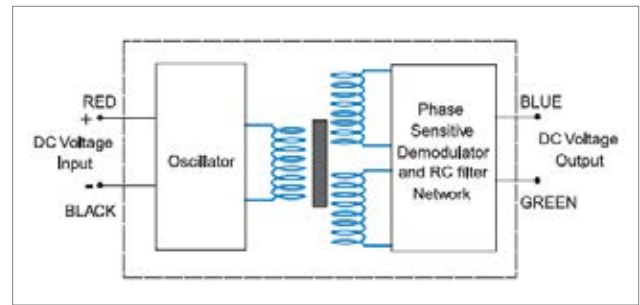

ACCESSORIES

PART NUMBER	DESCRIPTION
C003-0057	Mating connector assembly consisting of: connector MS3106A-14S-6S (mates with MS3101A-14S-6P),
G000-0000	Replacement AGD #7 Gaging Tip
C000-0036	Cable Assembly: 15 Feet of 6 conductor, 24 AWG vinyl cable terminated with C003-0057. (Note: Operating temperature for cable is -22 $^{\circ}$ F to +176 $^{\circ}$ F); Color Code: A – Brown, B – White, C – Black
N001-0025	3/4 X 16 UNF-1B Hex Jam Nut
1000-0012	Oscillator/ Demodulator

DC-DC OPERATION WITH OPTIONAL OSCILLATOR/DEMODULATOR

To facilitate prototyping, or in instances where the preference is a DC in - DC out system, any of the standard Series 310-320 can be used in conjunction with the Series 1000 Oscillator/ Demodulator. Designed to work together, the DC system gives the same level of performance as provided by the AC LVDT alone. The high level DC output voltage can be directly interfaced with analog

circuits as well as data acquisition cards, PLCs, or A/D converters. Provisions for customizing the Series 1000 to provide zero offsets and nonstandard gains allow a simple and cost effective method of tailoring a system to meet individual customer requirements. Detailed connection information can be found in the Accessories portion of this catalog.

SYSTEM SPECIFICATIONS *(Combined Performance of LVDT and 1000-0012)*

NON-LINEARITY	$\leq \pm 0.25\%$ FS (Best Fit Straight Line)
INPUT	± 14.5 to ± 28.0 VDC, ± 100 mA Max; Internal regulation and input voltage reversal protection provided
OUTPUT	Adjustable to ± 5.0 VDC at end of linear stroke, via SPAN adjustment
FREQUENCY RESPONSE (-3dB)	1000 Hz Min. (Electrical only, Mechanical response limited by spring)
OUTPUT RIPPLE	< 0.03 VRMS Max.
TEMPERATURE COEFFICIENTS	< $\pm 0.0035\%$ FS/ $^{\circ}$ F Zero, < $\pm 0.02\%$ Reading/ $^{\circ}$ F Span
TEMPERATURE RANGE	LVDT: -67 $^{\circ}$ F to +220 $^{\circ}$ F (-55 $^{\circ}$ C to +104 $^{\circ}$ C) Operating, -67 $^{\circ}$ F to +275 $^{\circ}$ F (-55 $^{\circ}$ C to +135 $^{\circ}$ C) Storage; Osc/Dem: +32 $^{\circ}$ F to +158 $^{\circ}$ F (0 $^{\circ}$ C to +70 $^{\circ}$ C) Operating, -67 $^{\circ}$ F to +257 $^{\circ}$ F (-55 $^{\circ}$ C to +125 $^{\circ}$ C) Storage

For more detailed information about these options, please contact the factory.

INTERTECHNOLOGY
1-800-465-1600
INC.

19 Waterman Ave. Toronto, Ont. M4B1Y2
Tel: 416-445-5500 Fax: 416-445-1170
Toll Free: 1-800-465-1600
Email: sales@intertechnology.com
Website: www.intertechnology.com