

Fluid-Damped Single-Point Load Cell

FEATURES

- Capacities 2–50 kg
- Painted steel construction
- OIML R60 and NTEP approved
- IP66 protection
- Available with metric and UNC threads
- **Optional**
 - Stainless steel construction

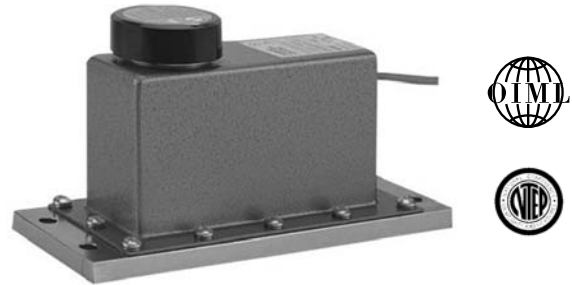

APPLICATIONS

- Multi-head filling machines
- Check weighing
- Grading machines
- Liquid filling
- Dynamic weighing

The Model 240 brings load cell adaptability into check weighing and grading applications.

Approved to OIML R60 and NTEP standards, sealed to IP66 level and available in coated steel or stainless steel, the Model 240 is suitable for most wash-down applications.

DESCRIPTION

Model 240 is specifically designed to be used where fast acquisition of a stable load signal is paramount. The Model 240's unique fluid damping system allows the load cell to be used in applications that previously required the use of LVDT's or similar types of measuring devices.

The two additional sense wires feed back the voltage reaching the load cell. Complete compensation of changes in lead resistance due to temperature change and/or cable extension, is achieved by feeding this voltage into the appropriate electronics.

OUTLINE DIMENSIONS in millimeters

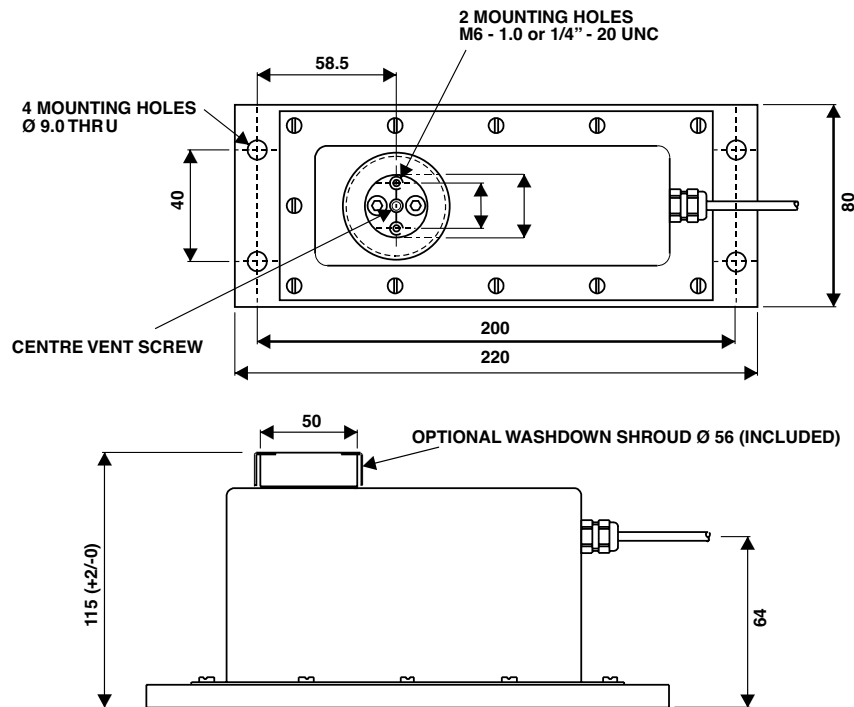

Fluid-Damped Single-Point Load Cell

SPECIFICATIONS				
PARAMETER	VALUE			UNIT
Rated capacity—R.C. (E_{max})	2, 3, 5, 7, 10, 15, 20, 30, 50**			kg
OIML accuracy class	NTEP	Non-Approved	C3*	
Maximum no. of intervals (n)	5000	1000	3000	
$Y = E_{max}/V_{min}$	12000	1750	9000	Maximum available
Rated output—R.O.	2.0			mV/V
Rated output tolerance	0.2			±mV/V
Zero balance	0.1			±mV/V
Zero return, 30 min.	0.033	0.050	0.015	±% of applied load
Total error	0.050	0.025	0.015	±% of rated output
Temperature effect on zero	0.0026	NA	0.0026	±% of rated output/°C
Temperature effect on output	0.0010	NA	0.0010	±% of rated output/°C
Temperature range, compensated	-10 to +40			°C
Temperature range, safe	-30 to +70			°C
Maximum safe central overload	150			% of R.C.
Ultimate central overload	300			% of R.C.
Excitation, recommended	10			VDC or VAC RMS
Excitation, maximum	15			VDC or VAC RMS
Input impedance	415±15			Ω
Output impedance	350±3			Ω
Insulation resistance	>1000			MΩ
Cable length	To suit			m
Cable type	6-wire, braided, polyurethane, silicone gel impregnation			Standard
Construction	Painted mild steel***			
Environmental protection	IP66			

* 50% utilization

** 2 and 3 kg are not approved by NTEP or OIML

*** Stainless steel available

All specifications subject to change without notice.

WIRING SCHEMATIC DIAGRAM

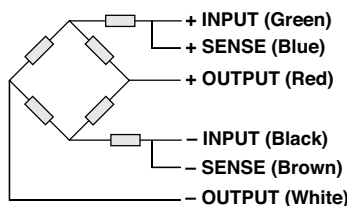

Disclaimer

ALL PRODUCTS, PRODUCT SPECIFICATIONS AND DATA ARE SUBJECT TO CHANGE WITHOUT NOTICE.

Vishay Precision Group, Inc., its affiliates, agents, and employees, and all persons acting on its or their behalf (collectively, "Vishay Precision Group"), disclaim any and all liability for any errors, inaccuracies or incompleteness contained herein or in any other disclosure relating to any product.

The product specifications do not expand or otherwise modify Vishay Precision Group's terms and conditions of purchase, including but not limited to, the warranty expressed therein.

Vishay Precision Group makes no warranty, representation or guarantee other than as set forth in the terms and conditions of purchase. **To the maximum extent permitted by applicable law, Vishay Precision Group disclaims (i) any and all liability arising out of the application or use of any product, (ii) any and all liability, including without limitation special, consequential or incidental damages, and (iii) any and all implied warranties, including warranties of fitness for particular purpose, non-infringement and merchantability.**

Information provided in datasheets and/or specifications may vary from actual results in different applications and performance may vary over time. Statements regarding the suitability of products for certain types of applications are based on Vishay Precision Group's knowledge of typical requirements that are often placed on Vishay Precision Group products. It is the customer's responsibility to validate that a particular product with the properties described in the product specification is suitable for use in a particular application.

No license, express, implied, or otherwise, to any intellectual property rights is granted by this document, or by any conduct of Vishay Precision Group.

The products shown herein are not designed for use in life-saving or life-sustaining applications unless otherwise expressly indicated. Customers using or selling Vishay Precision Group products not expressly indicated for use in such applications do so entirely at their own risk and agree to fully indemnify Vishay Precision Group for any damages arising or resulting from such use or sale. Please contact authorized Vishay Precision Group personnel to obtain written terms and conditions regarding products designed for such applications.

Product names and markings noted herein may be trademarks of their respective owners.