

## Damped Load Cells for Rotary Filling Machines

### FEATURES

- Capacities: 3 kg, 17 lbs, 23 lbs
- Stainless steel construction
- Insensitive to rotary dynamic forces
- Single-point performance
- Rotary speed to 13 rpm at 1m radius
- Sealed wash down configuration

### APPLICATIONS

- Rotary filling machines

### DESCRIPTION

The 1430 is uniquely designed to reduce weighing errors resulting from dynamic forces occurring on rotary liquid filling machines. The 1430 will provide high weighing accuracies when operated over a range of 0 to 13 rpm at a mounting location up to 1 meter radius.

The sealed stainless steel construction of the Model 1430 provides safe operation in applications subjected to



caustic or heavy wash down environments. The rugged construction provides significant overload protection both in the weighing axis as well as against side loading. Side loads, such as occurring in bottle jams of up to 300 kg, have been applied to units with no significant zero change.

The 1430 features adjustable viscous damping for shorter settling times and for faster machine cycles.

### OUTLINE DIMENSIONS in millimeters

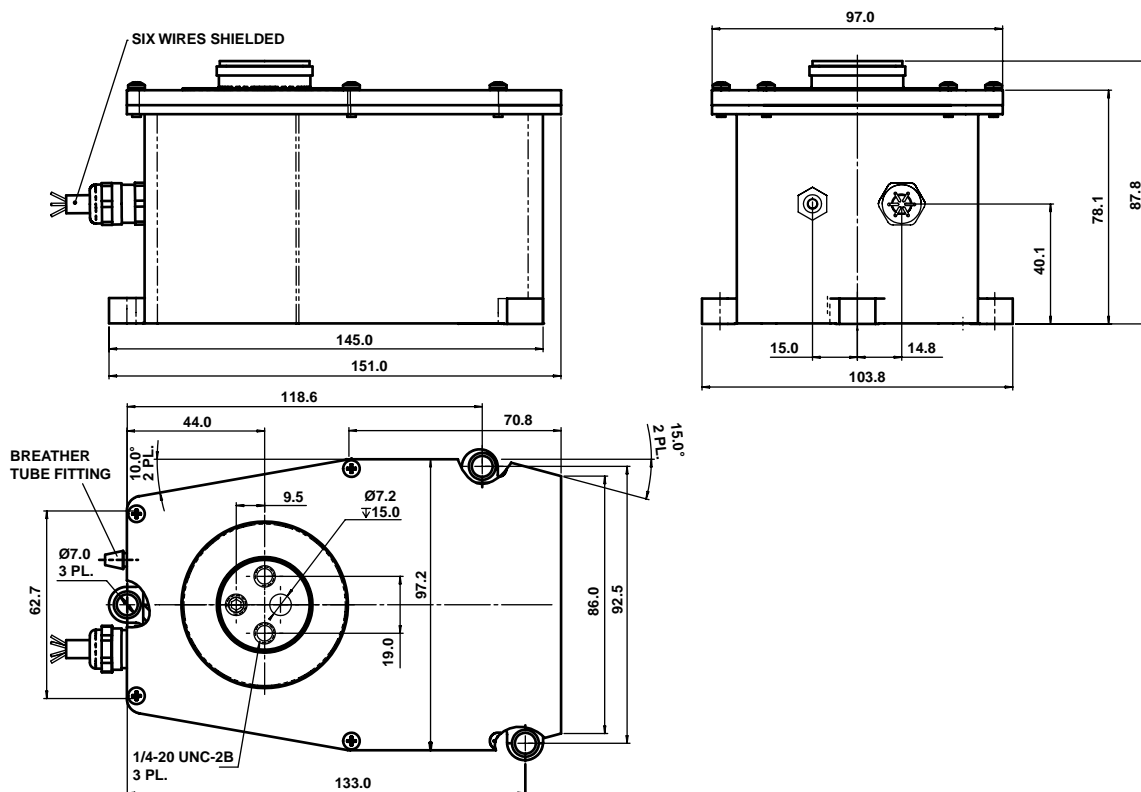

## Damped Load Cells for Rotary Filling Machines

SPECIFICATIONS		
PARAMETER	VALUE	UNIT
Rated capacity—R.C.	3	kg
Rated capacity—R.C.	17, 23	lb
TH Accuracy class	C1	
Maximum no. of intervals (n)	1000	
Rated output—R.O.	2	mV/V
Rated output tolerance	0.3	±mV/V
Zero balance—3 kg: (3 kg std.), 17 lb, 23 lb:	-0.6000±0.0500 ±0.2000	mV/V
Total static error at room temperature per OIML	0.03	±% of R.O.
Dynamic error: speed range of 0 to 15 rpm, rotational radius of 1m, load placed on platform located 14 cm above top surface of load-cell & connected by 3/4" or 20 mm dia. steel shaft	0.04	±% of the static reading at same load
Creep and zero return (30 min.)	0.05	±% of load
Temperature effect on zero	0.010	±% of R.O./°C
Temperature effect on output	0.003	±% of load/°C
Temperature range, compensated	+5 to +40	°C
Temperature range, safe	-30 to +70	°C
Maximum safe static overload, positive	160 <sup>(2)</sup>	% of R.C.
Maximum safe static overload, negative	-120	% of R.C.
Ultimate static overload (central loading)	300	% of R.C.
Excitation, recommended	10	VDC or VAC RMS
Excitation, maximum	15	VDC or VAC RMS
Input impedance	415±15	Ω
Output impedance	350±3	Ω
Insulation resistance	>2000	MΩ
Cable type	6-wire, 26 AWG, shielded, PVC jacket	
Cable length	6	m
Construction	Aluminum sensor enclosed in stainless steel box	
Damping	Internal silicone fluid damping <sup>(1)</sup>	

<sup>(1)</sup> Silicone fluid is shipped separately from load cell, dosed in syringe. Silicone fluid is filled in cylinder before installation of load cell.

<sup>(2)</sup> Factory adjusted to 170% of R.C.

All specifications subject to change without notice.

### Wiring Schematic Diagram

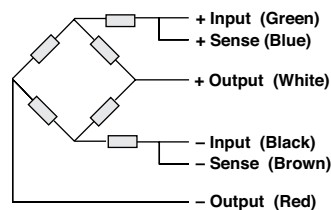

## Disclaimer

ALL PRODUCTS, PRODUCT SPECIFICATIONS AND DATA ARE SUBJECT TO CHANGE WITHOUT NOTICE.

Vishay Precision Group, Inc., its affiliates, agents, and employees, and all persons acting on its or their behalf (collectively, "Vishay Precision Group"), disclaim any and all liability for any errors, inaccuracies or incompleteness contained herein or in any other disclosure relating to any product.

The product specifications do not expand or otherwise modify Vishay Precision Group's terms and conditions of purchase, including but not limited to, the warranty expressed therein.

Vishay Precision Group makes no warranty, representation or guarantee other than as set forth in the terms and conditions of purchase. **To the maximum extent permitted by applicable law, Vishay Precision Group disclaims (i) any and all liability arising out of the application or use of any product, (ii) any and all liability, including without limitation special, consequential or incidental damages, and (iii) any and all implied warranties, including warranties of fitness for particular purpose, non-infringement and merchantability.**

Information provided in datasheets and/or specifications may vary from actual results in different applications and performance may vary over time. Statements regarding the suitability of products for certain types of applications are based on Vishay Precision Group's knowledge of typical requirements that are often placed on Vishay Precision Group products. It is the customer's responsibility to validate that a particular product with the properties described in the product specification is suitable for use in a particular application.

No license, express, implied, or otherwise, to any intellectual property rights is granted by this document, or by any conduct of Vishay Precision Group.

The products shown herein are not designed for use in life-saving or life-sustaining applications unless otherwise expressly indicated. Customers using or selling Vishay Precision Group products not expressly indicated for use in such applications do so entirely at their own risk and agree to fully indemnify Vishay Precision Group for any damages arising or resulting from such use or sale. Please contact authorized Vishay Precision Group personnel to obtain written terms and conditions regarding products designed for such applications.

Product names and markings noted herein may be trademarks of their respective owners.