

## Aluminum High Capacity Single-Point Load Cell

### FEATURES

- Capacities 50–635 kg
- Aluminum construction
- Single-point 600 x 600 mm platform
- OIML R60 and NTEP approved
- IP66 protection
- Available with metric and UNC threads
- **Optional**
  - EEx ia IIC T4 hazardous area approval
  - FM approval available

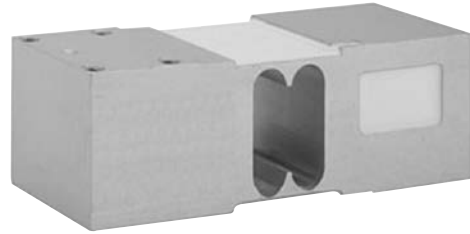

### APPLICATIONS

- Large platform scales
- Hanging scales
- Check weighing

### DESCRIPTION

Model 1260 is a high performance, high capacity single-point load cell designed for direct mounting of large platforms.

The rugged construction offers high immunity to side forces making it suitable for a wide range of weighing applications, including bench scales and check weighing.

A special humidity resistant protective coating assures long-term stability over the entire compensated temperature range.

For hazardous environments this load cell has an EEx ia IIC T4 level of approval.

The two additional sense wires feed back the voltage reaching the load cell. Complete compensation of changes in lead resistance due to temperature change and/or cable extension, is achieved by feeding this voltage into appropriate electronics.

### OUTLINE DIMENSIONS in millimeters

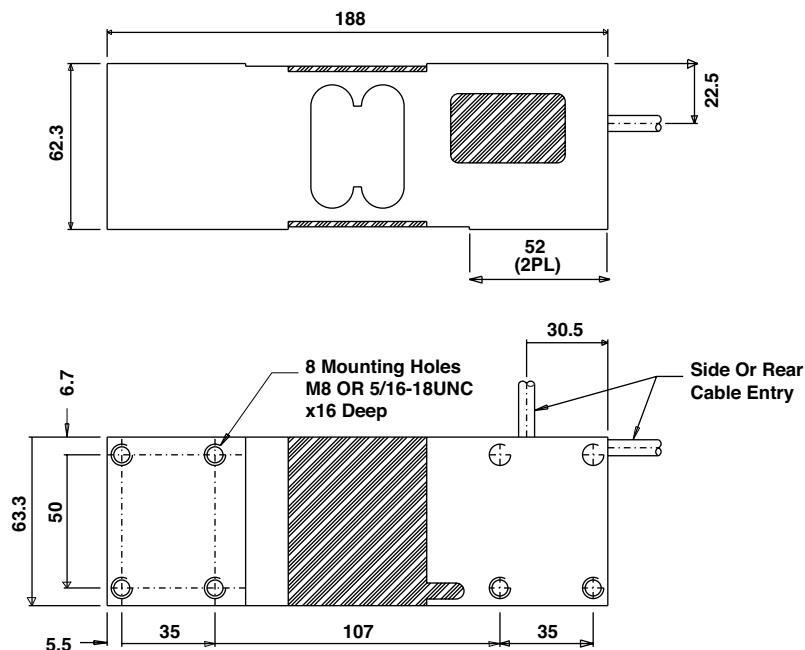

## Aluminum High Capacity Single-Point Load Cell

SPECIFICATIONS				
PARAMETER	VALUE			UNIT
Rated capacity—R.C. (E <sub>max</sub> )	50, 75, 100, 150, 250, 300, 500, 635			kg
NTEP/OIML accuracy class	NTEP	Non-Approved	C3*	
Maximum no. of intervals (n)	5000 single	1000	3000	
Y = E <sub>max</sub> /V <sub>min</sub>	1000	3333	15000	Maximum available
Rated output—R.O.	2.0			mV/V
Rated output tolerance	0.2			±mV/V
Zero balance	0.2			±mV/V
Zero return, 30 min.	0.0330	0.0300	0.0170	±% of applied load
Total error	0.0350	0.0500	0.0200	±% of rated output
Temperature effect on zero	0.0028	0.0100	0.0023	±% of rated output/°C
Temperature effect on output	0.0011	0.0030	0.0010	±% of applied load/°C
Eccentric loading error	0.0020	0.0050	0.0033	±% of rated load/cm
Temperature range, compensated	-10 to +40			°C
Temperature range, safe	-20 to +70			°C
Maximum safe central overload	150			% of R.C.
Ultimate central overload	300			% of R.C.
Excitation, recommended	10			VDC or VAC RMS
Excitation, maximum	15			VDC or VAC RMS
Input impedance	415±15			Ω
Output impedance	350±3			Ω
Insulation resistance	>2000			MΩ
Cable length	3			m
Cable type	6-wire, braided, polyurethane, dual floating screen			Standard
Construction	Plated (anodized) aluminum			
Environmental protection	IP66			
Platform size (max)	600 x 600			mm
Recommended torque	16.0			N*m

\* 50% utilization

All specifications subject to change without notice.

### Wiring Schematic Diagram

(Balanced temperature compensation)

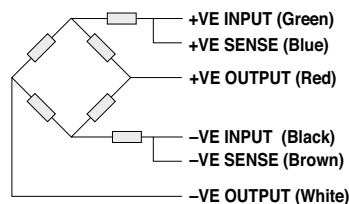

## Disclaimer

ALL PRODUCTS, PRODUCT SPECIFICATIONS AND DATA ARE SUBJECT TO CHANGE WITHOUT NOTICE.

Vishay Precision Group, Inc., its affiliates, agents, and employees, and all persons acting on its or their behalf (collectively, "Vishay Precision Group"), disclaim any and all liability for any errors, inaccuracies or incompleteness contained herein or in any other disclosure relating to any product.

The product specifications do not expand or otherwise modify Vishay Precision Group's terms and conditions of purchase, including but not limited to, the warranty expressed therein.

Vishay Precision Group makes no warranty, representation or guarantee other than as set forth in the terms and conditions of purchase. **To the maximum extent permitted by applicable law, Vishay Precision Group disclaims (i) any and all liability arising out of the application or use of any product, (ii) any and all liability, including without limitation special, consequential or incidental damages, and (iii) any and all implied warranties, including warranties of fitness for particular purpose, non-infringement and merchantability.**

Information provided in datasheets and/or specifications may vary from actual results in different applications and performance may vary over time. Statements regarding the suitability of products for certain types of applications are based on Vishay Precision Group's knowledge of typical requirements that are often placed on Vishay Precision Group products. It is the customer's responsibility to validate that a particular product with the properties described in the product specification is suitable for use in a particular application.

No license, express, implied, or otherwise, to any intellectual property rights is granted by this document, or by any conduct of Vishay Precision Group.

The products shown herein are not designed for use in life-saving or life-sustaining applications unless otherwise expressly indicated. Customers using or selling Vishay Precision Group products not expressly indicated for use in such applications do so entirely at their own risk and agree to fully indemnify Vishay Precision Group for any damages arising or resulting from such use or sale. Please contact authorized Vishay Precision Group personnel to obtain written terms and conditions regarding products designed for such applications.

Product names and markings noted herein may be trademarks of their respective owners.