

Aluminum Single-Point Load Cell

FEATURES

- Capacities 3–90 kg
- Aluminum construction
- Single-point 400 x 400 mm platform
- NTEP approved
- IP65 protection
- Available with metric and UNC threads
- **Optional**
 - EEx ia IIC T4 hazardous area approval
 - FM approval available
 - IP67 available



APPLICATIONS

- Bench scales
- Counting scales
- Grocery scales

DESCRIPTION

Model 1010 is a single-point load cell designed for direct mounting of low cost, low capacity weighing platforms.

Its use in large platforms, combined with its high accuracy and low cost, makes this load cell ideally suited for a large range of weighing applications, including bench scales and counting scales.

A special humidity resistant protective coating is available which ensures long-term reliability. For hazardous environments this load cell has EEx ia IIC T4 level approved option.

Model 1010's built-in overload stop can provide mechanical protection against overloading.

The two additional sense wires feed back the voltage reaching the load cell. Complete compensation of changes in lead resistance due to temperature change and/or cable extension is achieved by feeding this voltage into the appropriate electronics.

OUTLINE DIMENSIONS in millimeters

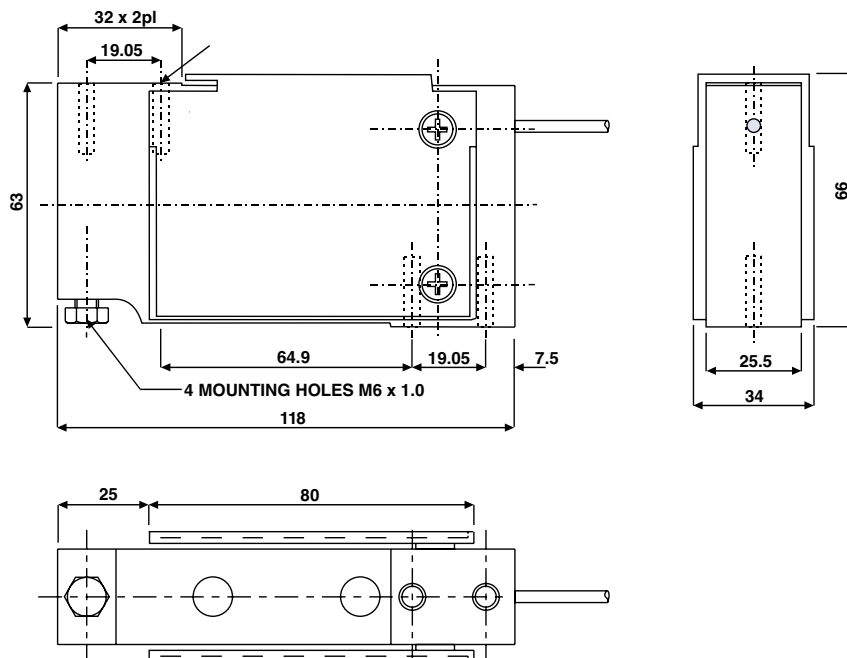

Aluminum Single-Point Load Cell

SPECIFICATIONS			
PARAMETER	VALUE*		UNIT
Rated capacity—R.C. (E_{max})	3, 5, 7, 10, 15, 20, 30, 50, 90		kg
NTEP/OIML accuracy class	NTEP	Non-Approved	
Maximum no. of intervals (n)	5000 single	3000	
$Y = E_{max}/V_{min}$	10000	10000	Maximum available
Rated output—R.O.	2.0		mV/V
Rated output tolerance	0.2		±mV/V
Zero balance	0.2		±mV/V
Zero return, 30 min.	0.0330	0.0170	±% of applied load
Total error (per OIML R60)	0.0200	0.0200	±% of rated output
Temperature effect on zero	0.0023	0.004	±% of rated output/°C
Temperature effect on output	0.001	0.0010	±% of applied load/°C
Eccentric loading error	0.0057	0.0074	±% of rated load/cm
Temperature range, compensated	-10 to +40		°C
Temperature range, safe	-20 to +70		°C
Maximum safe central overload	150		% of R.C.
Ultimate central overload	300		% of R.C.
Excitation, recommended	10		VDC or VAC RMS
Excitation, maximum	15		VDC or VAC RMS
Input impedance	415±15		Ω
Output impedance	350±3		Ω
Insulation resistance	>2000		MΩ
Cable length	1.0		m
Cable type	6 wire, PVC, single floating screen		Standard
Construction	Plated (anodize) aluminum		
Environmental protection	IP65**		
Platform size (max)	400 x 400		mm
Recommended torque	Up to 30 kg: 7.0 50 kg and up: 10.0		N-m

* 1010 is non-balanced load cell (non-balanced bridge), 1015 is balanced

** IP67 available upon request

All specifications subject to change without notice.

WIRING SCHEMATIC DIAGRAM (1010)
(Unbalanced bridge configuration)

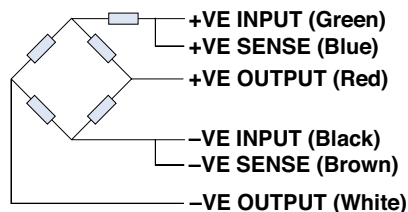

WIRING SCHEMATIC DIAGRAM (1015)
(Balanced temperature compensation)

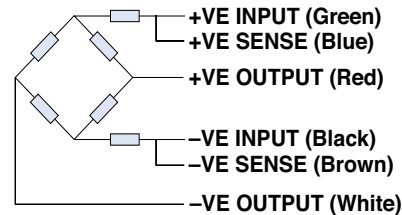

Disclaimer

ALL PRODUCTS, PRODUCT SPECIFICATIONS AND DATA ARE SUBJECT TO CHANGE WITHOUT NOTICE.

Vishay Precision Group, Inc., its affiliates, agents, and employees, and all persons acting on its or their behalf (collectively, "Vishay Precision Group"), disclaim any and all liability for any errors, inaccuracies or incompleteness contained herein or in any other disclosure relating to any product.

The product specifications do not expand or otherwise modify Vishay Precision Group's terms and conditions of purchase, including but not limited to, the warranty expressed therein.

Vishay Precision Group makes no warranty, representation or guarantee other than as set forth in the terms and conditions of purchase. **To the maximum extent permitted by applicable law, Vishay Precision Group disclaims (i) any and all liability arising out of the application or use of any product, (ii) any and all liability, including without limitation special, consequential or incidental damages, and (iii) any and all implied warranties, including warranties of fitness for particular purpose, non-infringement and merchantability.**

Information provided in datasheets and/or specifications may vary from actual results in different applications and performance may vary over time. Statements regarding the suitability of products for certain types of applications are based on Vishay Precision Group's knowledge of typical requirements that are often placed on Vishay Precision Group products. It is the customer's responsibility to validate that a particular product with the properties described in the product specification is suitable for use in a particular application.

No license, express, implied, or otherwise, to any intellectual property rights is granted by this document, or by any conduct of Vishay Precision Group.

The products shown herein are not designed for use in life-saving or life-sustaining applications unless otherwise expressly indicated. Customers using or selling Vishay Precision Group products not expressly indicated for use in such applications do so entirely at their own risk and agree to fully indemnify Vishay Precision Group for any damages arising or resulting from such use or sale. Please contact authorized Vishay Precision Group personnel to obtain written terms and conditions regarding products designed for such applications.

Product names and markings noted herein may be trademarks of their respective owners.