

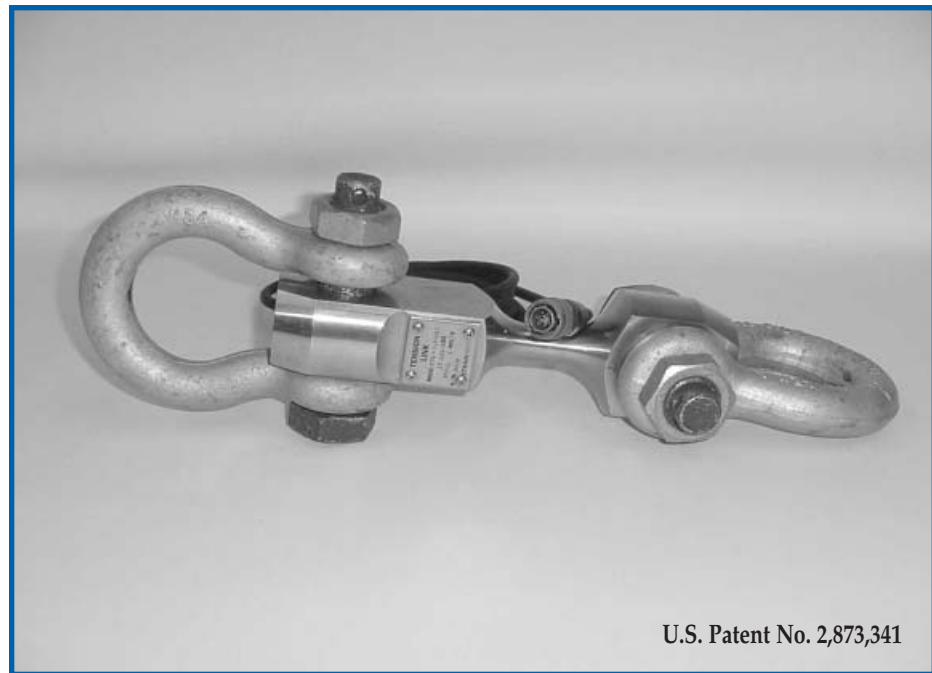

Force Sensing Tension Links for Anchor and Chain Shackles

STL Series

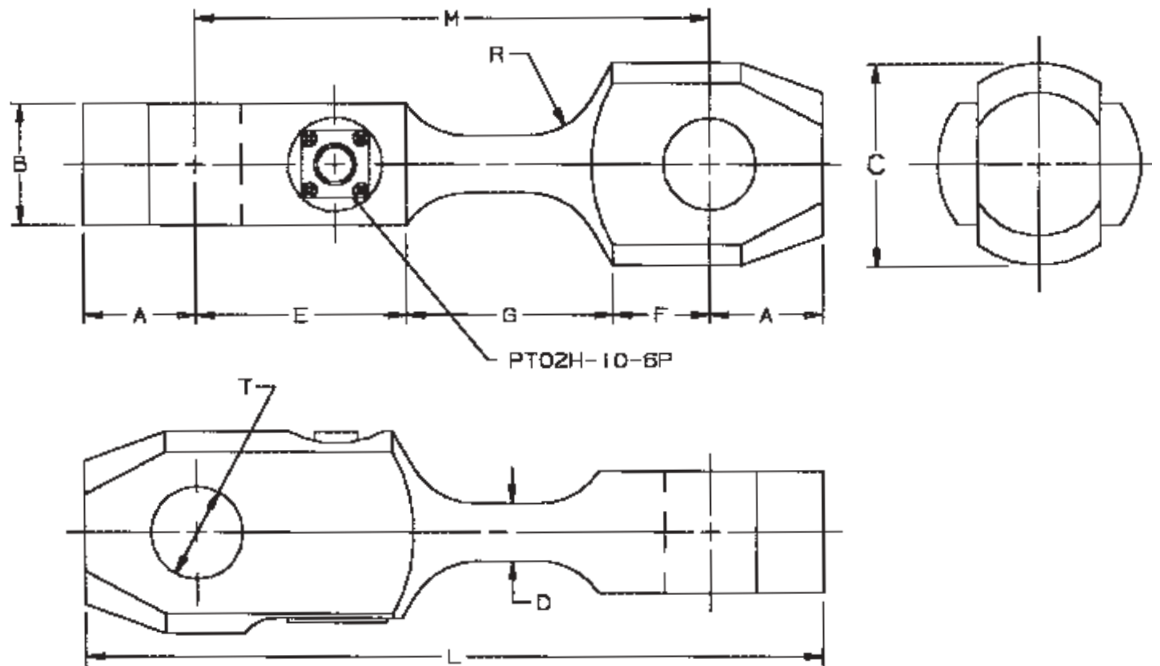

U.S. Patent No. 2,873,341

Force Sensing Tension Links for Anchor and Chain Shackles

Tension Link Model No.	Shackle Size	CAP. Lbs.	A	B	C Dia.	D Dia.	E	F	G	L	M	R Rad.	T Dia.	Safety Factor	Weight Lbs.
STL-0.75*	5/16	1,500	1/2	7/16	1	0.384	2-1/8	1/4	1-5/8	5	4	1/2	0.406	4.2	1
STL-1*	3/8	2,000	9/16	9/16	1-1/8	0.427	2-3/16	5/16	1-3/4	5-3/8	4-1/4	1/2	0.469	4.2	1
STL-1.5*	7/16	3,000	5/8	5/8	1-7/16	0.505	2-1/4	5/16	1-15/16	5-3/4	4-1/2	1/2	0.531	4.2	1
STL-2*	1/2	4,000	3/4	11/16	1-9/16	0.572	2-5/16	3/8	2-1/16	6-1/4	4-3/4	1/2	0.656	4.2	1
STL-3.25*	5/8	6,500	15/16	15/16	2	0.779	2-9/16	9/16	2-3/8	7-3/8	5-1/2	1/2	0.781	4.1	1
STL-4.75	3/4	9,500	1-1/8	1-1/8	2-3/16	0.635	2-5/8	3/4	2-5/8	8-1/4	6	1/2	0.906	3.0	4
STL-6.5	7/8	13,000	1-1/4	1-5/16	2-7/16	0.695	2-3/4	7/8	2-7/8	9	6-1/2	1	1.031	3.0	6
STL-8.5	1	17,000	1-3/8	1-9/16	2-11/16	0.764	2-11/16	1-1/16	3	9-1/2	6-3/4	1	1.156	3.0	8
STL-9.5	1-1/8	19,000	1-9/16	1-11/16	2-13/16	0.797	2-3/4	1-1/4	3-1/8	10-1/4	7-1/8	1	1.281	3.0	9
STL-12	1-1/4	24,000	1-3/4	1-7/8	3-1/16	0.873	2-11/16	1-7/16	3-3/8	11	7-1/2	1	1.438	3.0	12
STL-13.5	1-3/8	27,000	1-7/8	2-1/16	3-5/16	0.916	2-7/8	1-1/2	3-1/2	11-5/8	7-7/8	1	1.563	3.0	14
STL-30	1-1/2	60,000	1-13/16	2-3/16	3-7/16	1.274	2-15/16	1-7/16	4	12	8-3/8	1	1.688	3.0	16
STL-40	1-3/4	80,000	2-1/4	2-11/16	4-1/16	1.478	3-1/8	1-7/8	4-5/8	14-1/8	9-5/8	1	2.063	3.0	25
STL-50	2	100,000	2-1/2	3-1/16	4-1/2	1.614	3-1/4	2-1/16	5-1/16	15-3/8	10-3/8	1	2.313	3.0	32
STL-80	2-1/2	160,000	3-1/8	3-3/4	5-3/8	2.054	3-1/2	2-5/8	6-1/8	18-1/2	12-1/4	1	2.875	3.0	56
STL-110	3	220,000	3-11/16	4-5/8	6-3/8	2.397	3-3/4	3-1/2	6-5/8	21-1/4	13-7/8	1-1/2	3.375	3.0	95
STL-140	3-1/2	280,000	4-1/4	4-7/8	6-7/8	2.696	4-1/16	4	7-5/16	23-7/8	15-3/8	1-1/2	3.875	3.0	120
STL-175	4	350,000	4-3/4	5-1/8	7-7/16	3.008	4-7/16	4-7/16	7-7/8	26-1/4	16-3/4	1-1/2	4.375	3.0	190

* Aluminum Alloy: 7075-T6; Hard Coat Finish: Rockwell C-60. All others 17-4 Stainless Steel, H-1025
All dimensions in inches.

ORDERING INFORMATION

STL - 110 (SS) X

