



Fatigue Rated Universal Flat Load Cells®

The best features required by fatigue applications are provided for in the structure of the Strainert Flat Load Cell®.

The structure of the Flat Load Cell® is simple and compact, consisting of an inner loading hub and an outer supporting flange bridged smoothly by a uniformly continuous solid shear web. Strainert gages are installed and sealed inside small gage holes along the neutral axis of the web. Structural stress raisers are avoided. The lowest deflection and highest natural frequency of any available load cell are thus obtained, along with the highest resistance to extraneous forces. Mechanical and Dynamic Properties of Flat Load Cells® are fully tabulated.

In all other similar, Low Profile Load Cells the shear web is cut up into so many "spokes", not because a most efficient structure would require it, but to provide a manageable arrangement for the installation of shear gages on external surfaces, which then have to be sealed and protected by suitable covers. Both the shear web cutouts and sealing covers are undesirable sources of fatigue failures, avoided in the Flat Load Cell®.

Long fatigue life (10^9 cycles) and stability of the Flat Load Cell® is mainly due to low strain levels the shear gages are subjected to: $\pm 500\mu\epsilon$ FS for completely reversed "C/R" rating and $750\mu\epsilon$ FS for unidirectional "U/D" rating at $\pm 2\text{-mV/V}$ and 3-mV/V output signal levels respectively.

Linearity and symmetry of output signal in tension and compression are obtained by equal straining of all shear gages in the bridge circuit of the Flat Load Cell®.

Barometric or hydrostatic pressures, or vacuum environment do not produce erroneous output signals in Flat Load Cells®.

Allowable loads that Fatigue Rated Universal Flat Load Cells® will withstand for One Billion (10^9) cycles without failure are tabulated under Uni-Directional (U/D) and Completely Reversed (C/R) load headings.

In Specifications the relation is stated as (U/D) = 150% (C/R).

Allowable Intermediate Loads between Uni-Directional (U/D) and Completely Reversed (C/R) Loads can be read off the Limit Chart, where Completely Reversed (C/R) FS Fatigue Load Rating is defined as $\pm 100\%$ at One Billion Cycles. Peak Tension and Peak Compression, as well as Mean Tension and Mean Compression, loads are also given in % (C/R) FS.

Overload allowance in Fatigue Rated Flat Load Cells® can only be made at the expense of fatigue life. However, when the required service life of a load cell is less than one billion cycles, advantage may be taken of the reduced fatigue life and the cell may be rated at higher peak loads, per Overload Factors given in Specifications. Once this overload is applied, however, even for a few cycles, fatigue life of the cell must remain at the reduced value. Thus peak load ratings corresponding to one billion cycles should not be exceeded if long fatigue life is an important consideration for the load cell.

The load capacity and corresponding life of a Fatigue Rated Load Cell® is stated as follows:

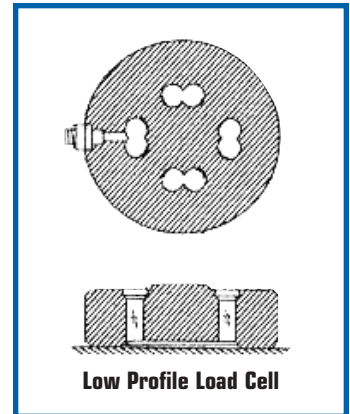
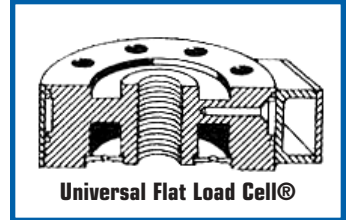

In the following example consider the case of ...

FFL(180/± 120) U(C)-(3/±2) SPKT

Where Uni-Directional (U/D) Rating is 180,000-lbs., and Completely Reversed (C/R) Rating is ±120,000-lbs.

From Limit Chart intermediate ratings are available. Say at +50% (+60,000-lb) Mean Tension Load

Allowable Peak Tension Load is +133% of 120,000-lbs. = +159,600-lbs.

Allowable Peak Compression Load is -33% of 120,000-lbs. = -39,600-lbs.

All at One Billion (10^9) Load Cycle Fatigue Life.

If, on the other hand, required service life of the load is only One Million (10^6) Load Cycles, then, from Overload Allowance Chart, all load ratings can be increased by Overload Factor of 1.10, thus:

(U/D) = 1.10 X 180,000 = 198,000-lbs.

(C/R) = 1.10 X (±120,000) = ±132,000-lbs.

At +50% (+60,000-lb) Mean Tension Load

Allowable Peak Tension = 1.10 X 159,600 = +175,560-lbs.

Allowable Peak Compression = 1.10 X (-39,600) = -43,560-lbs.

All at One Million (10^6) Load Cycle Fatigue Life.

FATIGUE RATED UNIVERSAL FLAT LOAD CELL® SPECIFICATIONS

	General Purpose	Precision
Fatigue Life	One Billion (10 ⁹) Cycles	
Capacity	U/D ^(*) = 150% C/R ^(*) , as tabulated	
Bridge Resistance (Nominal)	350 Ohms; Single or Dual Bridge	
Excitation Voltage	15V ac or dc (Maximum)	
Output Signal (Nominal)	3-mv/V U/D ^(*) ; 2-mv/V C/R ^(*)	
Compensated Range - °F	60 to 150	
Temperature Effect On Bridge Balance On Output Signal	0.0025% U/D ^(*) FS/°F 0.0025% of load/°F	0.0015% U/D ^(*) FS/°F 0.0015% of load/°F
Non-Repeatability	±0.05% U/D ^(*) FS	
Non-Linearity	±0.25% U/D ^(*) FS	±0.10% U/D ^(*) FS
Hysteresis	±0.15% U/D ^(*) FS	±0.10% U/D ^(*) FS
Bridge Balance	±1% U/D ^(*) FS	
Insulation Resistance Megohms (Minimum)	10,000	

U/D^(*) = Uni-Directional Fatigue Load Rating (Zero to Specified Maximum)

C/R^(*) = Completely Reversed Fatigue Load Rating (Plus & Minus)

NOTE: See pages 70 and 71 for further information on mechanical properties of Universal Flat Load Cells.

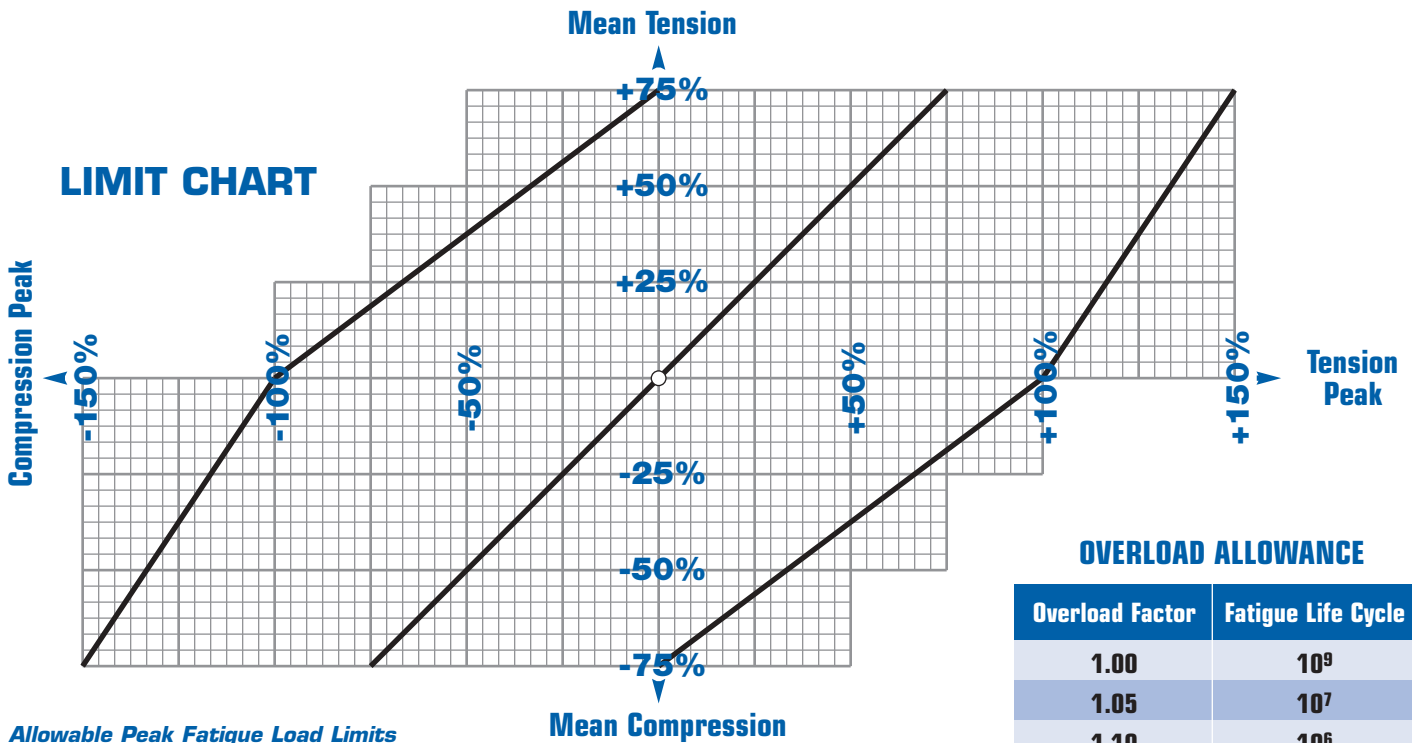

**Allowable Peak Fatigue Load Limits
Per Cent of Completely Reversed Fatigue
Load Rating (C/R) for One Billion (10⁹)
Life Cycles**

OVERLOAD ALLOWANCE

Overload Factor	Fatigue Life Cycle
1.00	10 ⁹
1.05	10 ⁷
1.10	10 ⁶
1.18	10 ⁵
1.33	10 ⁴



Fatigue Rated Universal Flat Load Cell® Dimensions

All Dimensions in inches and are subject to change without notice.
Certified Prints available on request.

FATIGUE RATING KIPS (Kilo-Pounds)		MODEL	A DIA.	B DIA.	C DIA.	D DIA.	E	F	G	H	K DIA.	k DIA.	L DIA.	M	N	T	LIFTING HOLES		BASIC MODEL	WT. LBS.
U/D* 3-mv/V	C/R* 2-mv/V																THREADS	BCD ‡		
1.8	±1.2	FFL(1.8/±1.2)U(C)-(3/±2)	11/16	1-7/16	2-1/2	2-11/16	3-23/32	15/16	2-13/16	1	11/32	7/32	1-15/16	1/32	5/16	3/8-16UNC-2B	NONE	NONE	FL2.5U-2	.6
4.5	±3	FFL(4.5/±3)U(C)-(3/±2)	11/16	1-11/16	3-3/16	3-7/16	4-15/32	15/16	2-15/16	1	13/32	9/32	2-7/16	1/32	3/8	7/16-20UNF-2B	NONE	NONE	FL10U-2 (Mod)	1.7
7.5	±5	FFL(7.5/±5)U(C)-(3/±2)	1-1/16	1-13/16	3-3/16	3-7/16	4-15/32	15/16	2-15/16	1	13/32	9/32	2-7/16	1/32	3/8	5/8-18UNF-2B	NONE	NONE	FL10U-2	1.7
15	±10	FFL(15/±10)U(C)-(3/±2)	1-5/8	2-7/8	4-7/8	5-1/8	6-7/16	1-3/8	3-3/4	1-1/2	19/32	13/32	3-3/4	1/16	1/2	1-14UNF-2B	NONE	NONE	FL25U-2	5.9
22-1/2	±15	FFL(22-1/2/±15)U(C)-(3/±2)	1-15/16	3-7/16	5-7/8	6-1/8	7-7/16	1-1/2	3-3/4	1-5/8	11/16	15/32	4-1/2	1/16	1/2	1-1/4-12N-2B	NONE	NONE	FL35U-2	9.4
30	±20	FFL(30/±20)U(C2)-(3/±2)	2-3/16	3-3/8	6-7/8	7-1/4	8-3/4	1-1/2	3-3/4	1-3/4	25/32	17/32	5-1/4	1/8	9/16	1-1/2-12N-2B	NONE	NONE	FL50U (C2)-2	15
45	±30	FFL(45/±30)U(C1)-(3/±2)	2-13/16	4-3/4	8-1/4	8-1/2	10-1/8	1-1/2	3-3/4	2-3/8	1-3/16	13/16	6-1/2	7/16	7/8	1-3/4-12N-2B	NONE	NONE	FL75U (C1)-2	30
60	±40	FFL(60/±40)U(C)-(3/±2)	3-3/8	5-5/8	9-1/4	9-1/2	11-1/8	1-1/2	3-3/4	2-3/4	1-3/16	13/16	7-1/4	7/16	7/8	2-12N-2B	NONE	NONE	FL100U-2	42
99	±66	FFL(99/±66)U(C)-(3/±2)	4-3/8	7	10-3/4	11-1/8	12-11/16	1-1/2	3-3/4	3-1/2	1-3/16†	13/16	8-3/4	9/16	1-1/8	2-3/8-12N-2B	3/8-16 UNC	3-1/8	FL150U-2	59.5
120	±80	FFL(120/±80)U(C)-(3/±2)	4-3/8	7-3/4	11-3/4	12-1/4	13-7/8	1-1/2	3-3/4	4	1-3/16†	13/16	9-3/4	11/16	1-1/4	2-3/8-12N-2B	3/8-16 UNC	3-1/2	FL200U-2	90
180	±120	FFL(180/±120)U(C)-(3/±2)	5	9-1/4	14-1/2	15	16-1/2	1-1/2	3-3/4	4	1-5/8†	1-1/16	11-3/4	11/16	1-3/4	3-12N-2B	3/8-16 UNC	4-1/8	FL300U-2	137
270	±180	FFL(270/±180)U(C)-(3/±2)	5-5/8	10-5/8	16-1/2	17	18-1/2	1-1/2	3-3/4	4-1/2	1-3/4†	1-3/16	13-1/2	7/8	1-3/8	3-1/2-8N-2B	3/8-16 UNC	4-5/8	FL400U-2	201

U/D*: Uni-directional load rating, from zero to maximum specified.

C/R*: Completely reversed load rating, plus and minus specified.

† These load cells have (16) hold-down bolt clearance holes of "K" diameter. All others have (8) holes.

‡ Bolt Circle Diameter.

Receptacle:	PT02H-10-6P	Cable:	#20(26x34) AWG., rubber insulation, shielded, rubber jacket, 4-Conductor (Standard Cable)
Mating Plug:	PT06A-10-6S (SR)	Function	Wire Code
Function	Pin	(+) Excitation	Red
(+) Excitation	A	(-) Excitation	Black
(-) Excitation	D	(+) Signal	Green
(+) Signal	B	(-) Signal	White
(-) Signal	C		

See pages 70 and 71 for further information on mechanical properties of Universal Flat Load Cells.

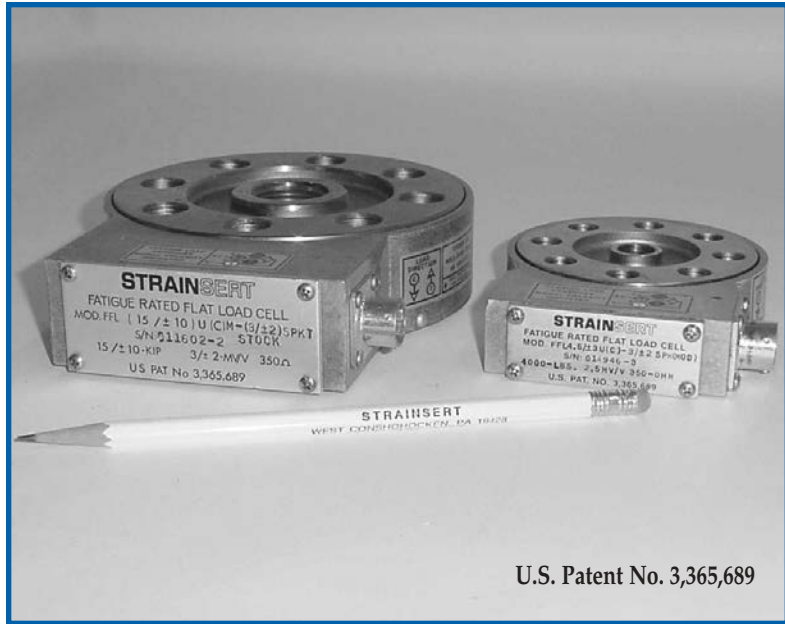
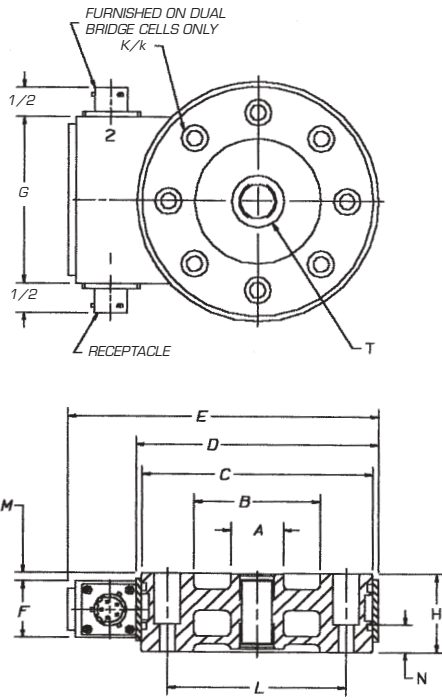

ORDERING INFORMATION

FFL (180/±120) U (C) - (3/±2) S P K T

T = Threaded Loading Hole
B = Thru Hole

K = Connector
W = Permanently Attached Cable

P = Precision 0.10% F.S. Non-Linearity
G = General Purpose 0.25% F.S. Non-Linearity

S = Single Bridge
D = Dual Bridge

2n = 2-mv/V (Nom.)* 2 = 2-mv/V (Standardized Output)
3n = 3-mv/V (Nom.)* 3 = 3-mv/V (Standardized Output)

(C) = Recessed Hold Down Bolt Holes

U = Universal

Capacity (Thousands of Pounds) 180,000-lbs. U/D
±120,000-lbs. C/R

FFL = Fatigue Rated Load Cell Series

* Exact output provided with calibration data.