

Tank Weighing Assembly

FEATURES

- Capacity ranges of 1000 to 75,000 pounds
- Mounts directly to the floor or structural support
- Self-checking with provisions for thermal expansion and contraction
- Insensitive to side loads and bending moments
- High output—well suited to high deadload/low liveload applications
- Load cells have matched outputs for multi-cell systems
- Excellent combined error and repeatability
- Accuracies exceed 0.1% with agitated loads
- Integral conduit adaptor
- *Sensorgage™* sealed to IP67 standards
- Factory Mutual System Approved for Classes I, II, III; Divisions 1 and 2; Groups A through G. Also, non-incendive ratings (No barriers!)
- **Optional**
 - Stainless steel, welded seal assemblies available

APPLICATIONS

- Tank, bin and hopper weighing
- Silo weighing
- Batching, blending, mixing, level and inventory monitoring

DESCRIPTION

The 65016-TWA is a mid to high capacity nickel-plated alloy steel weighing assembly.

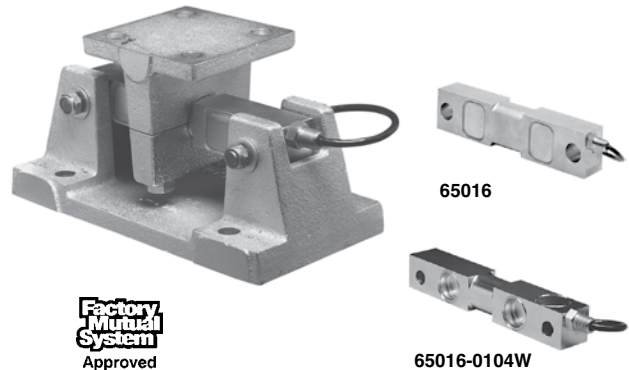

It has high side load rejection, and is able to withstand loads in all directions up to and exceeding its rated capacity without permanent damage or the threat of structural failure. This weighing assembly is also designed to move in the direction of thermal expansion, guaranteeing accurate measurements regardless of conditions. Nickel plating and IP67 rated sealing make this load cell suitable for use in outdoor applications as well as applications that are subject to high pressure wash down. For a higher degree of corrosion and water resistance please see 65016-0104W, the stainless steel and welded seal version of 65016.

This load cell is rated intrinsically safe by the Factory Mutual System (FM); making it suitable for use in potentially explosive environments.

OUTLINE DIMENSIONS in inches

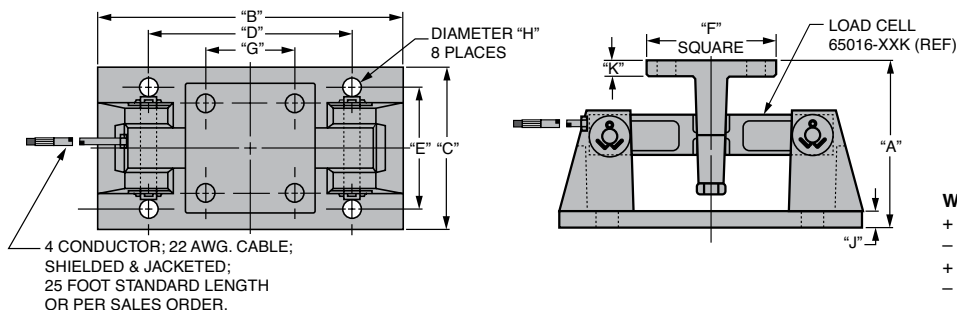

CAPACITY	A	B	C	D	E	F	G	H	J	K	WEIGHT
1k-5k	5.13	9.35	5.00	6.25	3.75	4.00	2.75	0.56	0.90	0.50	22.0
10k-35k	7.90	12.00	8.00	7.50	6.00	8.00	6.00	0.78	0.75	0.75	73.0
50k-75k	9.30	16.25	12.00	11.50	9.50	9.00	6.50	0.78	1.00	1.00	172.0

Capacities are in pounds.

Tank Weighing Assembly

SPECIFICATIONS		
PARAMETER	VALUE	UNIT
Rated capacity—R.C. (E_{max})	1k, 1.5k, 2.5k, 5k, 10k, 15k, 25k, 35k, 50k, 75k	lbs
NTEP/OIML accuracy class	Standard	
Maximum no. of intervals (n)	—	
Rated output—R.O.	3.0	mV/V
Rated output tolerance	0.25	±% mV/V
Zero balance	1.0	±% FSO
Combined error	0.03	±% FSO
Non-repeatability	0.01	±% FSO
Creep error (20 minutes)	0.03	±% FSO
Temperature effect on zero	0.0015	±% FSO/°F
Temperature effect on output	0.0008	±% of load/°F
Compensated temperature range	14 to 104 (–10 to 40)	°F (°C)
Operating temperature range	0 to 150 (–18 to 65)	°F (°C)
Storage temperature range	–60 to 185 (–50 to 85)	°F (°C)
Sideload rejection ratio	500:1	
Safe sideload	100	% of R.C.
Maximum safe central overload	150	% of R.C.
Ultimate central overload	300	% of R.C.
Excitation, recommended	15	VDC or VAC RMS
Excitation, maximum	25	VDC or VAC RMS
Input impedance	686–714	Ω
Output impedance	699–707	Ω
Insulation resistance at 50 VDC	>1000	MΩ
Material load cell	Nickel-plated alloy tool steel or stainless steel	
Material assembly	Zinc-plated cast steel	
Environmental protection	IP67	

FSO—Full Scale Output

All specifications subject to change without notice.

Disclaimer

ALL PRODUCTS, PRODUCT SPECIFICATIONS AND DATA ARE SUBJECT TO CHANGE WITHOUT NOTICE.

Vishay Precision Group, Inc., its affiliates, agents, and employees, and all persons acting on its or their behalf (collectively, "Vishay Precision Group"), disclaim any and all liability for any errors, inaccuracies or incompleteness contained herein or in any other disclosure relating to any product.

The product specifications do not expand or otherwise modify Vishay Precision Group's terms and conditions of purchase, including but not limited to, the warranty expressed therein.

Vishay Precision Group makes no warranty, representation or guarantee other than as set forth in the terms and conditions of purchase. **To the maximum extent permitted by applicable law, Vishay Precision Group disclaims (i) any and all liability arising out of the application or use of any product, (ii) any and all liability, including without limitation special, consequential or incidental damages, and (iii) any and all implied warranties, including warranties of fitness for particular purpose, non-infringement and merchantability.**

Information provided in datasheets and/or specifications may vary from actual results in different applications and performance may vary over time. Statements regarding the suitability of products for certain types of applications are based on Vishay Precision Group's knowledge of typical requirements that are often placed on Vishay Precision Group products. It is the customer's responsibility to validate that a particular product with the properties described in the product specification is suitable for use in a particular application.

No license, express, implied, or otherwise, to any intellectual property rights is granted by this document, or by any conduct of Vishay Precision Group.

The products shown herein are not designed for use in life-saving or life-sustaining applications unless otherwise expressly indicated. Customers using or selling Vishay Precision Group products not expressly indicated for use in such applications do so entirely at their own risk and agree to fully indemnify Vishay Precision Group for any damages arising or resulting from such use or sale. Please contact authorized Vishay Precision Group personnel to obtain written terms and conditions regarding products designed for such applications.

Product names and markings noted herein may be trademarks of their respective owners.