

Low Profile Platform Cell

FEATURES

- Rated capacities of 10 to 200 pounds
- Stainless steel construction
- Moment-compensated design for minimal sensitivity to moments induced by off-center loading
- *Sensorgage™* sealed to IP67 standards
- Factory Mutual System Approved for Classes I, II, III; Divisions 1 and 2; Groups A through G. Also, non-incendive ratings (No barriers!)



APPLICATIONS

- Single-point platform scales
- Bench, counting and deli scales
- Checkweighing scales
- Hopper scales and netweighing

DESCRIPTION

The 60051 is a low profile high precision, stainless steel, single point platform load cell.

This product's low profile makes it ideal for many low to mid range capacity weighing applications where space is at a premium. This load cell is most commonly used in platform scales, but can be adapted for use in many process weighing applications.

The stainless steel construction and IP67 sealing make this load cell ideal for very harsh environment applications. This load cell is specifically designed for use in corrosive and wet environments that are not appropriate for common aluminum load cells.

This product is rated intrinsically safe by the Factory Mutual System (FM); making it suitable for use in potentially explosive environments.

OUTLINE DIMENSIONS in inches

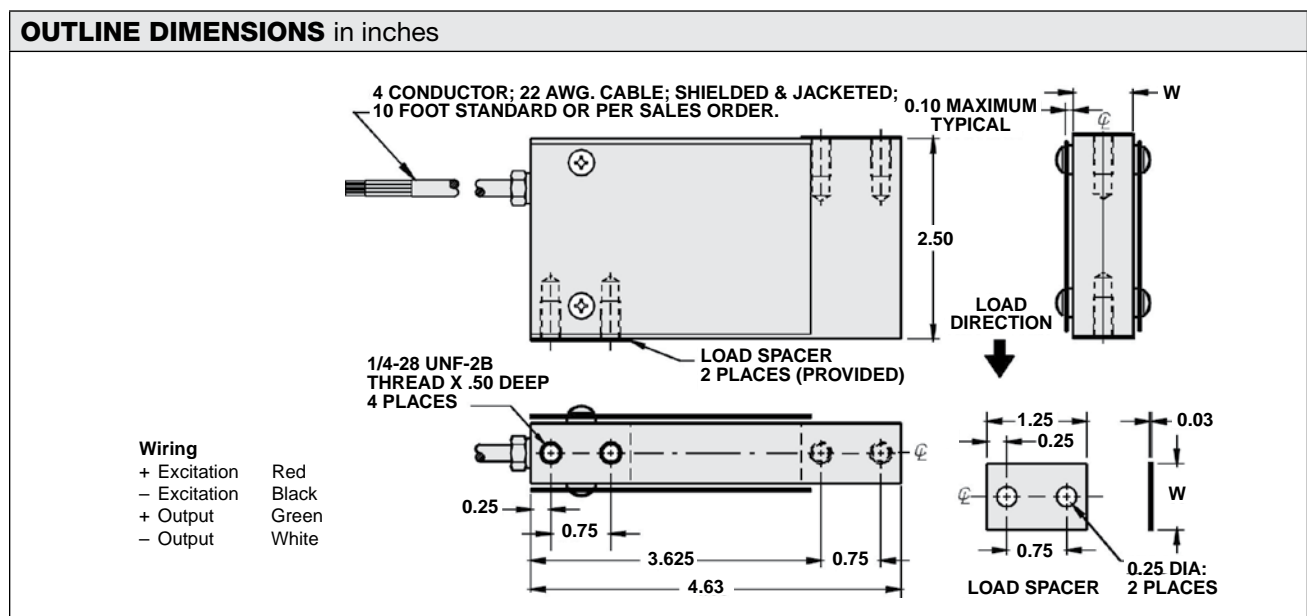

Low Profile Platform Cell

SPECIFICATIONS			
PARAMETER	VALUE		UNIT
Rated capacity—R.C. (E_{max})	10, 15, 25, 50, 100, 200		lbs
NTEP/OIML accuracy class	Standard		
Maximum no. of intervals (n)	—		
Rated output—R.O.	2.0		mV/V
Rated output tolerance	+0.25...-10		±% mV/V
Zero balance	1.0		±% FSO
Combined error	0.03		±% FSO
Non-repeatability	0.01		±% FSO
Creep error (20 minutes)	0.03		±% FSO
Temperature effect on zero	0.0015		±% FSO/°F
Temperature effect on output	0.0008		±% of load/°F
Compensated temperature range	14 to 104 (-10 to 40)		°F (°C)
Operating temperature range	0 to 150 (-18 to 65)		°F (°C)
Storage temperature range	-60 to 185 (-50 to 85)		°F (°C)
Maximum safe central overload	150		% of R.C.
Ultimate central overload	300		% of R.C.
Excitation, recommended	10		VDC or VAC RMS
Excitation, maximum	15		VDC or VAC RMS
Input impedance	380–450		Ω
Output impedance	349–355		Ω
Insulation resistance at 50 VDC	>1000		MΩ
Material	Stainless steel		
Environmental protection	IP67		
Moment compensation	10–25 lbs	50–200 lbs	
Moment sensitivity	0.015	0.100	±% of load/inch
Maximum moment	5 x capacity	6 x capacity	lbs-inches
Platform size	8 x 10	12 x 12	inches

FSO—Full Scale Output

All specifications subject to change without notice.

Disclaimer

ALL PRODUCTS, PRODUCT SPECIFICATIONS AND DATA ARE SUBJECT TO CHANGE WITHOUT NOTICE.

Vishay Precision Group, Inc., its affiliates, agents, and employees, and all persons acting on its or their behalf (collectively, "Vishay Precision Group"), disclaim any and all liability for any errors, inaccuracies or incompleteness contained herein or in any other disclosure relating to any product.

The product specifications do not expand or otherwise modify Vishay Precision Group's terms and conditions of purchase, including but not limited to, the warranty expressed therein.

Vishay Precision Group makes no warranty, representation or guarantee other than as set forth in the terms and conditions of purchase. **To the maximum extent permitted by applicable law, Vishay Precision Group disclaims (i) any and all liability arising out of the application or use of any product, (ii) any and all liability, including without limitation special, consequential or incidental damages, and (iii) any and all implied warranties, including warranties of fitness for particular purpose, non-infringement and merchantability.**

Information provided in datasheets and/or specifications may vary from actual results in different applications and performance may vary over time. Statements regarding the suitability of products for certain types of applications are based on Vishay Precision Group's knowledge of typical requirements that are often placed on Vishay Precision Group products. It is the customer's responsibility to validate that a particular product with the properties described in the product specification is suitable for use in a particular application.

No license, express, implied, or otherwise, to any intellectual property rights is granted by this document, or by any conduct of Vishay Precision Group.

The products shown herein are not designed for use in life-saving or life-sustaining applications unless otherwise expressly indicated. Customers using or selling Vishay Precision Group products not expressly indicated for use in such applications do so entirely at their own risk and agree to fully indemnify Vishay Precision Group for any damages arising or resulting from such use or sale. Please contact authorized Vishay Precision Group personnel to obtain written terms and conditions regarding products designed for such applications.

Product names and markings noted herein may be trademarks of their respective owners.