

MODEL 60008

LOW CAPACITY PLATFORM CELL

APPLICATIONS

- Single-point platform scales
- Checkweighing scales
- Hopper scales and netweighing
- Ultra low capacity weighing

FEATURES

- Rated capacities of 1 to 100 pounds
- Constructed of high quality alloy steel
- Nickel plated for outstanding corrosion resistance
- High sensitivity for measurements in grams range
- Precision overload stop provides optimum protection under adverse loading conditions
- Moment-compensated design for minimal sensitivity to moments induced by off-center loading
- Integral loading bracket
- **Sensorgage™** sealed to IP61 standards
- **Cell Guard™** Two Year Warranty
- Factory Mutual System Approved for Classes I, II, III; Divisions 1 and 2; Groups A through G. Also, **Non-Incendive** ratings (No Barriers!).
- ISO 9001 Certified manufacturing facilities



ISO
9001

Factory
Mutual
System
Approved



Model 60008 Performance Specifications

Rated Capacities (lbs): 1, 2, 5, 10, 20, 25, 50, 100
 Full Scale Output (FSO): 2.0 mV/V +25% / -10%

Accuracy Class:	<u>Standard</u>
Combined Error % FSO	≤ .03
Non-Linearity % FSO	≤ .03
Hysteresis % FSO	≤ .02
Creep Error % FSO	≤ .03 in 20 minutes
Temperature Effect on:	
•Zero % FSO/°F	≤ 0.0015
•Output % of Load/°F	≤ 0.0008
Non-Repeatability % FSO	≤ .01
Zero Balance % FSO	≤ 1.0
Insulation Resistance	> 1000 Mohms at 50VDC
Compensated Temperature Range	14° to 104°F / -10° to 40°C
Operating Temperature Range	0° to 150°F / -18° to 65°C
Storage Temperature Range	-60° to 185°F / -50° to 85°C
Input Resistance	380-450 Ohms
Output Resistance	349-355 Ohms
Recommended Excitation Voltage	10 Volts DC
Maximum Excitation Voltage	15 Volts DC
Safe Overload	150% of Rated Capacity
Ultimate Overload	300% of Rated Capacity
Sealing	Meets IP61 Standards
Material	Alloy Tool Steel
Finish	Electroless Nickel Plated

Moment Compensation:	<u>1 - 10 Lbs.</u>	<u>20 - 100 Lbs.</u>
•Moment Sensitivity	≤ 0.015 % of applied load per inch	≤ 0.100 % of applied load per inch
•Maximum Moment (lbs-inches)	6 inches x Capacity	6 inches x Capacity
•Platform Size (inches)	6 x 6	12 x 12
Deflection (inches ±10%):	<u>1 - 2 Lbs.</u>	<u>5 - 100 Lbs.</u>
	0.023	0.020

WIRING

FUNCTION	COLOR
+ Excitation	Red
- Excitation	Black
+ Output	Green
- Output	White

4 CONDUCTOR CABLE;
 22 AWG; SHIELDED &
 JACKETED; 10 FOOT
 STANDARD LENGTH OR
 PER SALES ORDER

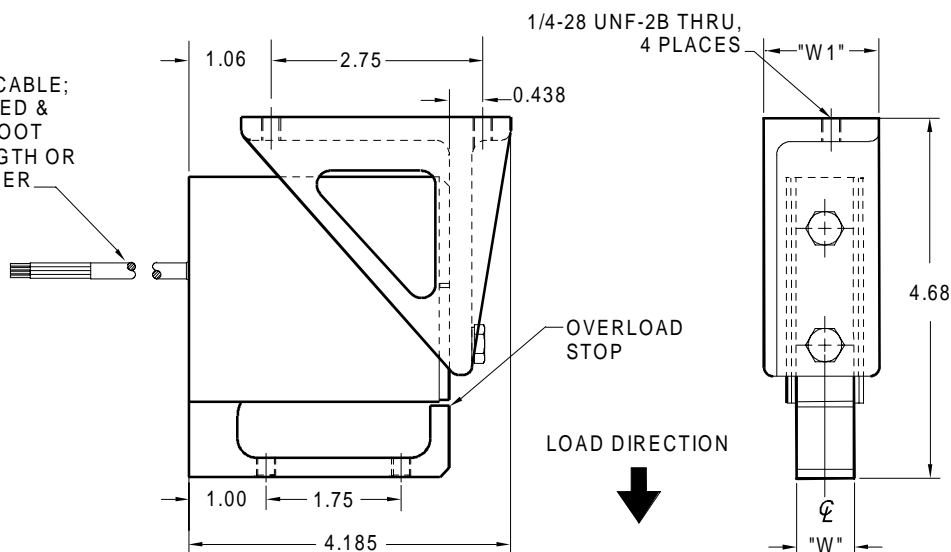

CAPACITY	W	W1	Weight
1 - 2	0.50	0.72	1.5
5 - 10	0.50	1.50	2.0
20 - 50	0.75	1.50	2.0
100	1.00	1.50	3.0

Dimensions are in inches. Capacities are in pounds. Specifications subject to change. Certified drawings are available.