

## Double-Ended Beam Load Cell

### FEATURES

- Capacities: 10k to 75k lbs
- Environmental protection: IP67 (DIN 40.050)
- Material: Stainless steel
- Certified to NTEP class III L, 10000 divisions
- **Optional**
  - FM approved for use in potentially explosive atmospheres

### APPLICATIONS

- Weighbridges
- Silos, tanks and hoppers

### DESCRIPTION

The 9423 is a medium capacity double-ended beam type load cell made of stainless steel.

This product is designed for use in certified truck and rail scales and is available in capacities from 10k to 75k lbs.



A reliable sealing and mechanical protection of the strain gage area is ensured by the use of potting compound with a metal cover.

This load cell is rated intrinsically safe by the FM system, making it suitable for use in potentially explosive atmospheres.

### OUTLINE DIMENSIONS in inches

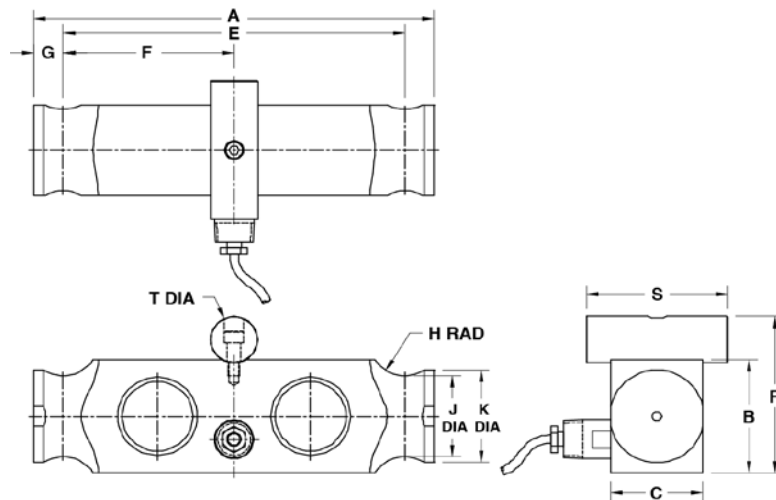

#### Cable specifications

Cable length: 9m (30 ft)

Excitation +	Red
Excitation -	Black
Output +	Green
Output -	White
Shield	Transparent

Cable screen is not connected to the load cell body.

Capacity (lbs)	10k, 15k, 20k, 25k	30k, 40k, 50k, 60k, 75k
A	8.00	8.50
B	1.94	2.45
C	1.44	1.95
E	7.12	7.25
F	3.56	3.62
G	0.44	0.63
H RAD	0.38	0.75
J	0.80	1.75
K	1.00	2.00
R	2.57	3.38
S	1.94	3.00
T	0.75	1.00

## Double-Ended Beam Load Cell

SPECIFICATIONS			
PARAMETER	VALUE		UNIT
Capacities	10k*, 15k*, 20k, 25k, 30k, 40k, 50k, 60k, 75k		lbs
Accuracy class according to NTEP	NTEP IIIIL	Non-Approved	
Max. no. of verification intervals	10000d		
Rated output (=S)	3		mV/V
Rated output tolerance	0.003		±mV/V
Zero balance	1.0		±% FSO
Combined error	0.0200	0.0300	±% FSO
Creep error (20-30 minutes)	0.0300	0.0300	±% applied load
Temperature effect on min. dead load output	0.0090 (0.0010)	0.0135 (0.0015)	±% FSO/5°C (1°F)
Temperature effect on sensitivity	0.0072 (0.0008)		±% applied load/5°C (1°F)
Compensated temperature range	-10 to +40 (+14 to 104)		°C (°F)
Operating temperature range	-53 to +93 -65 to +200)		°C (°F)
Safe load limit	150		% E <sub>max</sub>
Ultimate load	300		% E <sub>max</sub>
Safe side load limit	100		% E <sub>max</sub>
Excitation voltage recommended	10		V
Excitation voltage maximum	15		V
Input resistance	700±7		Ω
Output resistance	700±7		Ω
Insulation resistance	≥5000		MΩ
Environmental protection	IP67		
Element material	Stainless steel		ASTM

\* Capacities 10k and 15k are not NTEP approved.

FSO—Full Scale Output

Correct mounting of the load cells is essential to ensure optimum accuracy and performance. Further information is available upon request.

All specifications subject to change without notice.

## Disclaimer

ALL PRODUCTS, PRODUCT SPECIFICATIONS AND DATA ARE SUBJECT TO CHANGE WITHOUT NOTICE.

Vishay Precision Group, Inc., its affiliates, agents, and employees, and all persons acting on its or their behalf (collectively, "Vishay Precision Group"), disclaim any and all liability for any errors, inaccuracies or incompleteness contained herein or in any other disclosure relating to any product.

The product specifications do not expand or otherwise modify Vishay Precision Group's terms and conditions of purchase, including but not limited to, the warranty expressed therein.

Vishay Precision Group makes no warranty, representation or guarantee other than as set forth in the terms and conditions of purchase. **To the maximum extent permitted by applicable law, Vishay Precision Group disclaims (i) any and all liability arising out of the application or use of any product, (ii) any and all liability, including without limitation special, consequential or incidental damages, and (iii) any and all implied warranties, including warranties of fitness for particular purpose, non-infringement and merchantability.**

Information provided in datasheets and/or specifications may vary from actual results in different applications and performance may vary over time. Statements regarding the suitability of products for certain types of applications are based on Vishay Precision Group's knowledge of typical requirements that are often placed on Vishay Precision Group products. It is the customer's responsibility to validate that a particular product with the properties described in the product specification is suitable for use in a particular application.

No license, express, implied, or otherwise, to any intellectual property rights is granted by this document, or by any conduct of Vishay Precision Group.

The products shown herein are not designed for use in life-saving or life-sustaining applications unless otherwise expressly indicated. Customers using or selling Vishay Precision Group products not expressly indicated for use in such applications do so entirely at their own risk and agree to fully indemnify Vishay Precision Group for any damages arising or resulting from such use or sale. Please contact authorized Vishay Precision Group personnel to obtain written terms and conditions regarding products designed for such applications.

Product names and markings noted herein may be trademarks of their respective owners.