

# 642C SINGLE POINT LOAD CELL

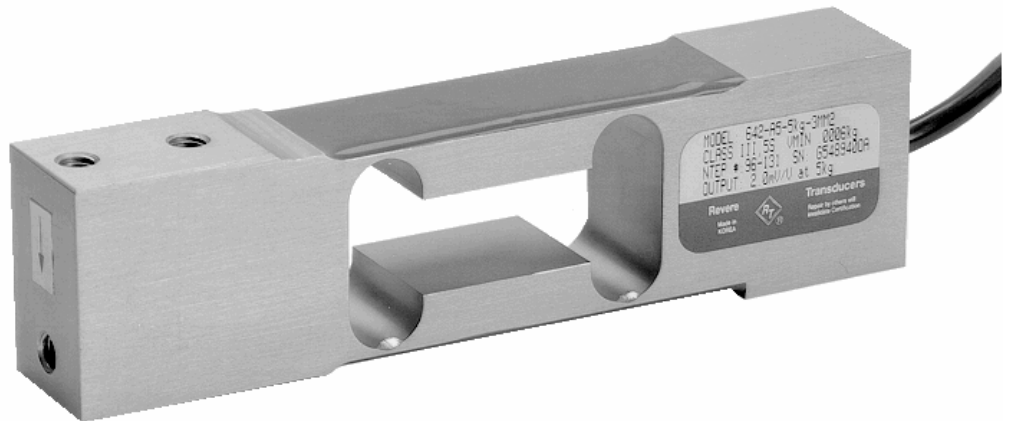

## DESCRIPTION:

The 642C is an aluminium single point (moment insensitive) load cell.

Single point load cells eliminate the need for flexures and levers thus greatly simplifying scale design and reducing cost. The 642C load cell is suitable for use in a wide range of packaging machinery, low capacity scales, checkweighers and general process weighing.

Full sealing ensures this product can be used in a variety of industrial applications.

This product fully meets the stringent Weights and Measures requirements throughout Europe.

## FEATURES:

- Silicon sealing protection for damp environments as standard
- Certified to OIML R-60, **3000d**
- Industry standard mounting configuration
- Moment insensitive, platform size to 400 x 400mm
- **CAPACITIES: 5 → 100kg**

# 642C: SPECIFICATIONS

Standard Capacities (=E <sub>max</sub> )	Kg	5, 10, 15, 20, 30, 50, 75, 100			
Accuracy Class According to OIML R-60			C1	C2	C3
Max. Number of Verification Intervals (n <sub>ic</sub> )			1000	2000	3000
Minimum Verification Interval (v <sub>min</sub> )			E <sub>max</sub> /6250	E <sub>max</sub> /6250	E <sub>max</sub> /6250
Accuracy According to Type Designation		CC	C1	C2	C3
Combined Error	%S	≤± 0.0500	≤± 0.0300	≤± 0.0230	≤± 0.0200
Non-Repeatability	%S	≤± 0.0200	≤± 0.0200	≤± 0.0100	≤± 0.0100
Minimum Dead Load Output Return <sup>1</sup>	%S	≤± 0.0500	≤± 0.0500	≤± 0.0250	≤± 0.0167
Creep Error (30 Minutes) <sup>1</sup>	%S	≤± 0.0600	≤± 0.0490	≤± 0.0245	≤± 0.0245
Creep Error (20-30 Minutes) <sup>1</sup>	%S	≤± 0.0200	≤± 0.0105	≤± 0.0053	≤± 0.0053
Temp. Effect on Min. Dead Load Output	%S/5 °C	≤± 0.0250	≤± 0.0112	≤± 0.0112	≤± 0.0112
Temp. Effect on Sensitivity	%S/5 °C	≤± 0.0250	≤± 0.0085	≤± 0.0060	≤± 0.0050
Minimum Dead Load	%E <sub>max</sub>	0			
Maximum Safe Over Load	%E <sub>max</sub>	150			
Ultimate Over Load	%E <sub>max</sub>	300			
Maximum Safe Side Load load	%E <sub>max</sub>	100			
Deflection at E <sub>max</sub>	mm	0.2, 0.20, 0.23, 0.25, 0.31, 0.46, 0.56, 0.6			
Excitation Voltage	V	5...15			
Maximum Excitation Voltage	V	18			
Rated Output (=S)	mV/V	2			
Tolerance on Rated Output	mV/V	≤± 0.2			
Zero Balance	%S	≤± 5			
Input Resistance	Ω	400 ± 20			
Output Resistance	Ω	350 ± 3.5			
Insulation Resistance	MΩ	≥ 5000			
Compensated Temperature Range	°C	-10...+40			
Operating Temperature Range	°C	-30...+65			
Storage Temperature Range	°C	-40...+70			
Element Material		Aluminium Alloy (2024)			
Sealing (IEC 68-2-30)		IP65			
Eccentric load effect <sup>2</sup>	%S	0.01			
Maximum Platform Size	mm	400x400			
Recommended Torque on Fixation Bolts	Nm	15 - 20			

1 Applies for the temperature range -10 to +40 °C

2 Measured with ½ Rated Load at 25% platform diameter.

Accuracy class C1, C2 and C3 are in agreement with the OIML recommendation R-60.

Correct mounting of the load cell is essential to ensure optimum performance. The maximum platform sizes given are those recommended to ensure that (a) the system meets Weights and Measures requirements and (b) damage is not done to the load cell through excessive torque. Overload stops should be set with loads placed **within the recommended** platform size. Further information is available on request.

## REVERE TRANSDUCERS EUROPE B.V.

Ramshoorn 7  
Postbus 6909, 4802 HX Breda  
The Netherlands  
Tel: (+31) 76-5480700  
Fax: (+31) 76-5412854  
E-mail: info@revere.nl

## REVERE TRANSDUCERS INC.

14192 Franklin Avenue  
Tustin, CA 92780-7016  
U.S.A.  
Tel: (+1) 714.731.1234  
Fax: (+1) 714.731.2019  
E-mail: info@reveretransducers.com

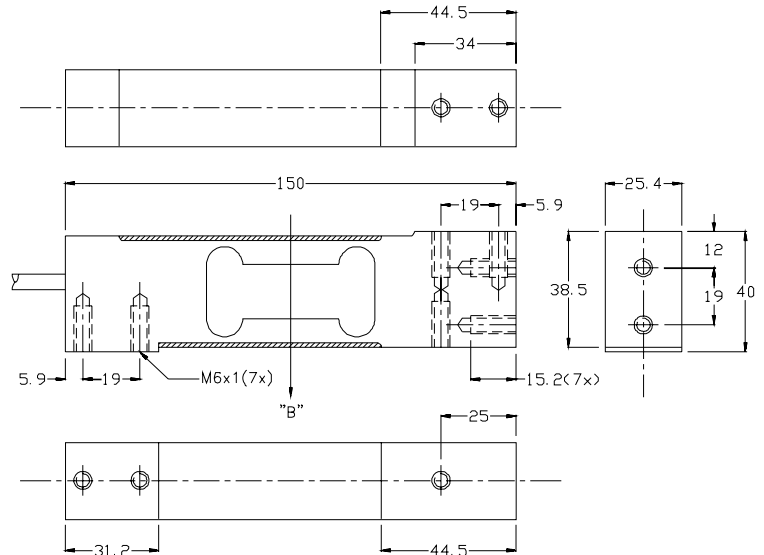

### Cable specifications:

Cable length 3m.  
Excitation + Red  
Excitation - Black  
Output + Green  
Output - White  
Sense + Blue  
Sense - Brown  
Shield Clear

Cable screen is not connected to load cell body.

B	Central Load Axis
All Threads M6x1 (15 Deep min.)	

### Attention:

Dimensions: mm.  
All dimension tolerances according to ISO 2768m, unless otherwise specified.

All specifications subject to change without notice

2/3/70/02 E

**INTERTECHNOLOGY**  
INC.

19 Waterman Ave, Toronto, Ont. M4B1Y2  
Ph#416-445-5500 Fax#416-445-1170  
Toll Free: 1-800-465-1600  
Email: sales@intertechnology.com  
Website: www.intertechnology.com