

SR- Series Slip Ring Assembly

Models SR10M, SR20M, SR36M

- 10, 20, and 36 circuit slip rings
- Instrumentation quality rings and brushes
- Rugged stainless steel construction
- Lightweight and compact
- Permanently lubricated bearings
- Color coded terminals
- Sealed against dust

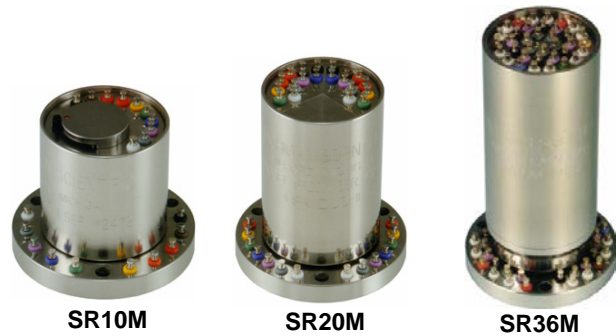

Description

Michigan Scientific's *SR Series Slip Ring Assemblies* are used for a variety of applications requiring 10, 20, or 36 circuit connections. They are designed to mount on the end of a rotating shaft and make electrical connections to strain gages, thermocouples, or other sensors that have been installed on rotating equipment. The slip ring brushes and rings are made of precious metals, which minimizes noise and enables the assemblies to be used for low level instrumentation signals. In addition, a high grade stainless steel case provides protection from dust and other contaminants.

The *SR10M* model is designed with a convenient, manually operated, brush lifter to extend the life of the slip ring assembly. When it is not necessary to make electrical connection through the slip ring, the brushes can be lifted off the rings, while the slip ring continues to rotate, thus reducing the amount of wear.

Connections to the slip ring assemblies are made through color coded solder terminals located on both the slip ring rotor and stator. Permanently lubricated bearings eliminate the need for routine cleaning and maintenance. The circuit options available on these slip ring models make them ideal for use in instrumentation applications where a substantial number of circuit connections are required.

Specifications

	SR10M	SR20M	SR36M
Circuits	10	20	36
Current Capacity per Circuit	500 mA	500 mA	250mA
Temperature Range*	-40°F to 250°F (-40°C to 121°C)	-40°F to 250°F (-40°C to 121°C)	-40°F to 250°F (-40°C to 121°C)
RPM Rating	12000 RPM	4000 RPM	2400 RPM
Maximum Peak Noise**	0.1Ω	0.1Ω	0.1Ω
Weight	6.5 oz. (184 g)	7.2 oz. (204 g)	9 oz. (255 g)
Length "A" (see back)	1.8 in (46 mm)	2.4 in (61 mm)	3.6 in (91 mm)
*For operation below 0°F, specify low temperature lubricant."			
** Resistance variation across slip ring contact.			

SR- Series Slip Ring Assembly

SR-Series Slip Ring Configuration

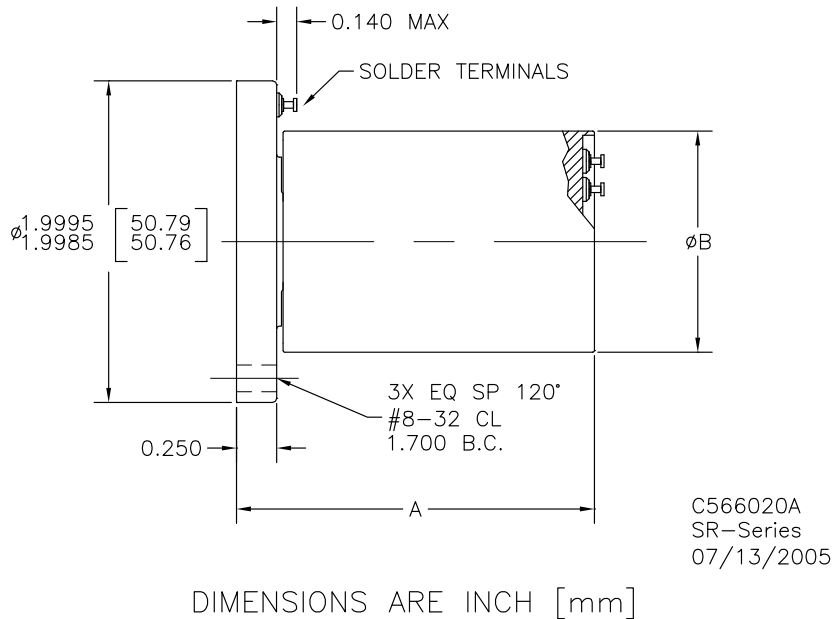

MODEL	A	B
SR10M	1.62 / 1.68*	1.375
SR20M	2.23	1.375
SR36M	3.51	1.440
*To top of brush lifter		

Mounting

The *SR Series Slip Ring Assemblies* can easily be mounted to the end of a shaft. An adapter may be required for mounting the slip ring to an instrumented shaft. The slip ring rotor is configured with three #8-32 clearance holes, 120° apart, used for mounting. Signal wires from the sensors can be routed along the outside diameter of the shaft or through the center of a hollow shaft. A slot must be machined in the shaft or adapter to open a pathway to the slip ring rotor terminals when signal leads are routed through the center of the shaft.

Contact Michigan Scientific for applications in which the slip ring assemblies are subjected to extreme vibration.

Ordering Options

For information regarding slip ring accessories, refer to the “Price List and Accessories” section.

INTERTECHNOLOGY
1-800-465-1600
INC.

19 Waterman Ave. Toronto, Ont. M4B1Y2
Tel: 416-445-5500 Fax: 416-445-1170
Toll Free: 1-800-465-1600
Email: sales@intertechnology.com
Website: www.intertechnology.com