

Slip Ring & Precision Encoder Assembly

Model SR10A/PE512

- 10 circuit slip ring with optical encoder
- 2 outputs of 512 ppr in quadrature
- 1 output of 1 ppr for an index pulse
- All pulses accurate within 5 arc-minutes
- Standard models sealed against dust
- Instrumentation quality rings and brushes
- Weatherproof units available



Description

The Michigan Scientific *Slip Ring and Precision Encoder Assemblies* are used for applications requiring both a slip ring and a precision encoder. These assemblies are available in both standard and weatherproof models. Designed to mount on the end of a rotating shaft, they make electrical connections to strain gages, thermocouples, or other rotating sensors, while simultaneously providing pulses to measure rotational velocity and angular position. The slip ring brushes and rings are made of precious metals, which minimize noise and enable the assemblies to be used for low level instrumentation signals.

This slip ring accepts up to 10 circuit connections and incorporates an optical encoder that generates 2 outputs of 512 pulses per revolution (ppr) in quadrature and a third output of 1 ppr. The quadrature feature detects the direction of rotation, and the 1 ppr is an index pulse used as a reference point when measuring angular position. True shaft position is indicated within 5 arc-minutes, resulting in high accuracy. This is particularly important when making measurements such as torsional vibration, instantaneous velocity, and angular position. Analog output signals for angular position and rotational speed can be obtained by using these models with Michigan Scientific's Frequency to Voltage Encoder Electronics.

Connections to the standard models are made through color coded solder terminals located on both the slip ring rotor and slip ring stator. For the weatherproof models, connections to the slip ring rotor are made through terminals or a military style connector. To provide complete weatherproof protection, the assemblies can be sealed with a rubber boot that protects the terminals on the slip ring stator, or with 3145 RTV silicone. Permanently lubricated bearings eliminate the need for routine cleaning and maintenance.

Slip Ring & Precision Encoder Assembly

Specifications

	SR10A/PE512	SR10MW/PE512	SR10AW/PE512/A
Circuits	10	10	10
Current Capacity	500 mA	500 mA	500 mA
Temperature Range*	--40°F to 212°F (-40°C to 100°C)	-40°F to 212°F (-40°C to 100°C)	-40°F to 212°F (-40°C to 100°C)
RPM Rating	10,000	2,000	2,000
Maximum Peak Noise**	0.1 Ω	0.1 Ω	0.1 Ω
Weight	15 oz. (425 g)	15 oz. (425 g)	15 oz. (425 g)
Length "A"	2.51 in (63.8 mm)	3.12 in (79.2 mm)	3.12 in (79.2 mm)
Diameter "D"	2.5 in (63.5 mm)	2.0 in (50.8 mm)	2.5 in (63.5 mm)
Rotor Connections	Terminals	Terminals	Connector

*For operation below 0°F, specify low temperature lubricant
 ** Resistance variation across slip ring contact

SR10A/PE512 Configuration

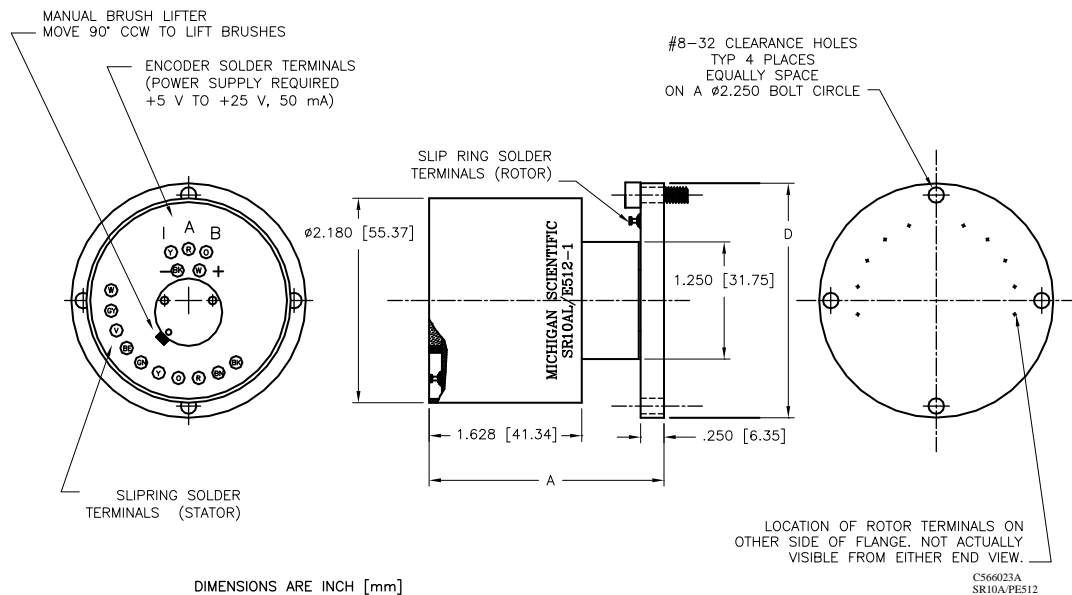

Mounting

These models can easily be mounted to the end of a shaft. Refer to the literature in the "Instrumentation Assemblies" and "Price List and Accessories" sections for examples of mounting adapters.

Contact Michigan Scientific for applications in which the slip ring assemblies are subjected to extreme vibration.

Ordering Options

The *Slip Ring and Precision Encoder Assemblies* are available with 256, 360, 500, or 512 pulses per revolution. For information regarding slip ring accessories, refer to the "Price List and Accessories" section.

INTERTECHNOLOGY
INC.
1-800-465-1600

19 Waterman Ave. Toronto, Ont. M4B1Y2
Tel: 416-445-5500 Fax: 416-445-1170
Toll Free: 1-800-465-1600
Email: sales@intertechnology.com
Website: www.intertechnology.com