

## PT9DN

### Cable Actuated Sensor Heavy Industrial • DeviceNET®

**Linear Position/Velocity to 550 inches (1400 cm)**

**Aluminum or Stainless Steel Enclosure Options**

**IP67 • NEMA 6 Protection**

#### General

<b>Full Stroke Range</b>	0-75 to 0-550 inches
<b>Electrical Signal Interface</b>	CANbus ISO 11898
<b>Protocol</b>	DeviceNET Version 2.0
<b>Accuracy</b>	± 0.10% full stroke
<b>Repeatability</b>	± 0.02% full stroke
<b>Resolution</b>	± 0.003% full stroke
<b>Measuring Cable Options</b>	nylon-coated stainless steel or thermoplastic
<b>Enclosure Material</b>	powder-painted aluminum or stainless steel
<b>Sensor</b>	plastic-hybrid precision potentiometer
<b>Potentiometer Cycle Life</b>	≥ 250,000 cycles
<b>Maximum Retraction</b>	see ordering information
<b>Acceleration</b>	
<b>Maximum Velocity</b>	see ordering information
<b>Weight, Aluminum (Stainless Steel) Enclosure</b>	8 lbs. (16 lbs.), max.

The PT9DN communicates via DeviceNET protocol with programmable controllers in factories and harsh environments requiring linear position measurements in ranges up to 550".

As a member of Celesco's innovative family of NEMA 4 rated cable-extension transducers, the PT9DN installs in minutes by simply mounting its body to a fixed surface and attaching its cable to the movable object. Perfect parallel alignment not required.

#### Output Signal

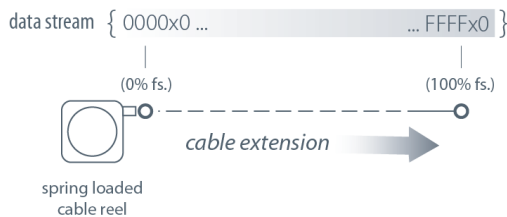

#### Electrical

<b>Input Voltage</b>	bus powered
<b>Input Current</b>	40 mA max.
<b>Address Setting (Node ID)</b>	0...63 set via DIP switches (default: 63)
<b>Baud Rate</b>	125K, 250K or 500K set via DIP switches
<b>EDS File</b>	available @ <a href="http://celesco.com/downloads">http://celesco.com/downloads</a>

#### Environmental

<b>Enclosure</b>	NEMA 4/4X/6, IP 67
<b>Operating Temperature</b>	-40° to 200°F (-40° to 90°C)
<b>Vibration</b>	up to 10 g to 2000 Hz maximum

**I/O Format**

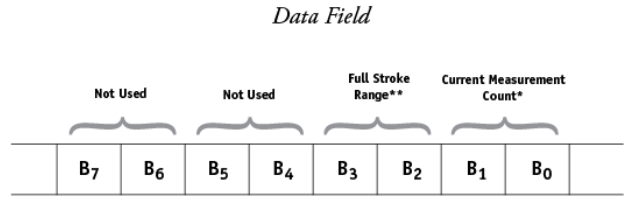
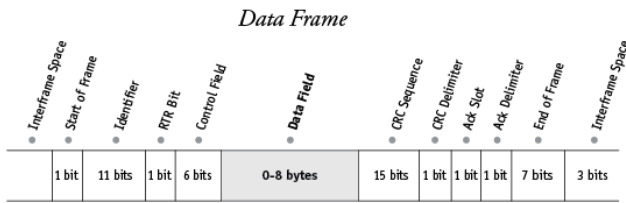

**\*Current Measurement Count**

The Current Measurement Count (CMC) is the output data that indicates the present position of the measuring cable.

The CMC is a 16-bit value that occupies the first two bytes (B<sub>0</sub> and B<sub>1</sub>) of the data field. B<sub>0</sub> is the LSB (least significant byte) and B<sub>1</sub> is the MSB (most significant byte).

The CMC starts at 0000H with the measuring cable fully retracted and continues upward to the end of the stroke range stopping at FFFFH. This holds true for all ranges.

**\*\*Full Stroke Range**

The Full Stroke Range (FSR) is a 16-bit value in the data field that expresses the full range of the sensor in inches. This value can be used to convert the actual count to units of measurement should the application require it.

The full stroke measurement range occupies the second two bytes (B<sub>2</sub> and B<sub>3</sub>) of the data field.

B<sub>2</sub> is the LSB (least significant byte) and B<sub>3</sub> is the MSB (most significant byte).

This value is expressed in inches.

Example:

Hex Value	Decimal Equivalent	Full Stroke Range
001E	30	30 inches

**Converting CMC to Inches**

If required, the CMC can easily be converted to a linear measurement expressed in inches instead of just counts.

This is accomplished by first dividing the CMC by 65,535 (total counts over the range) and then multiplying that value by the FSR:

$$\left( \frac{\text{CMC}}{65,535} \right) \times \text{FSR}$$

Example:

If the full stroke range is **30 inches** and the current position is **OFF2 Hex (4082 Decimal)** then,

$$\left( \frac{4082}{65,535} \right) \times 30.00 \text{ inches} = 1.87 \text{ inches}$$

**Address Setting (Node ID), Baud Rate and Bus Termination Settings**

**Address Setting (Node ID)**

The Address Setting (Node ID) is set via 6 switches located on the 8-pole DIP switch found on the DeviceNET controller board located inside the transducer.

The DIP switch settings are binary starting with switch number 1 (= 2<sup>0</sup>) and ending with switch number 6 (= 2<sup>5</sup>).

DIP-1 (2 <sup>0</sup> )	DIP-2 (2 <sup>1</sup> )	DIP-3 (2 <sup>2</sup> )	DIP-4 (2 <sup>3</sup> )	DIP-5 (2 <sup>4</sup> )	DIP-6 (2 <sup>5</sup> )	address (decimal)
0	0	0	0	0	0	0
1	0	0	0	0	0	1
0	1	0	0	0	0	2
...	...	...	...	...	...	...
1	1	1	1	1	1	63

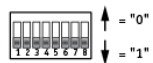

**Baud Rate**

The transmission baud rate may be either factory preset at the time of order or set manually at the time of installation.

The baud rate can be set using switches 7 & 8 on the 8-pole DIP switch found on the DeviceNET controller board located inside the transducer.

DIP-7	DIP-8	baud rate
0	0	125k
1	0	250k
0	1	500k
1	1	125k



**Bus Termination**

The setting of the internal bus termination resistor may be specified upon order or manually changed by the end user at the time of installation.

The bus termination resistor is activated setting switches 1 & 2 on the 2-pole DIP switch (located on the internal DeviceNET controller board) to the "ON" position.

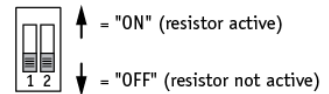

**DeviceNET Controller Board and DIP Switch Location**

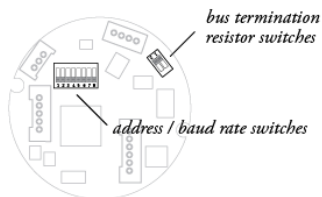

**Caution! Do Not Remove Spring-Side End Cover**  
removing spring-side end cover could cause spring to become unseated and permanently damaged.

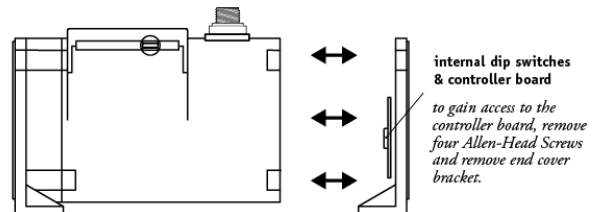

**Fig. 1 – Outline Drawing (18 oz. cable tension only)**

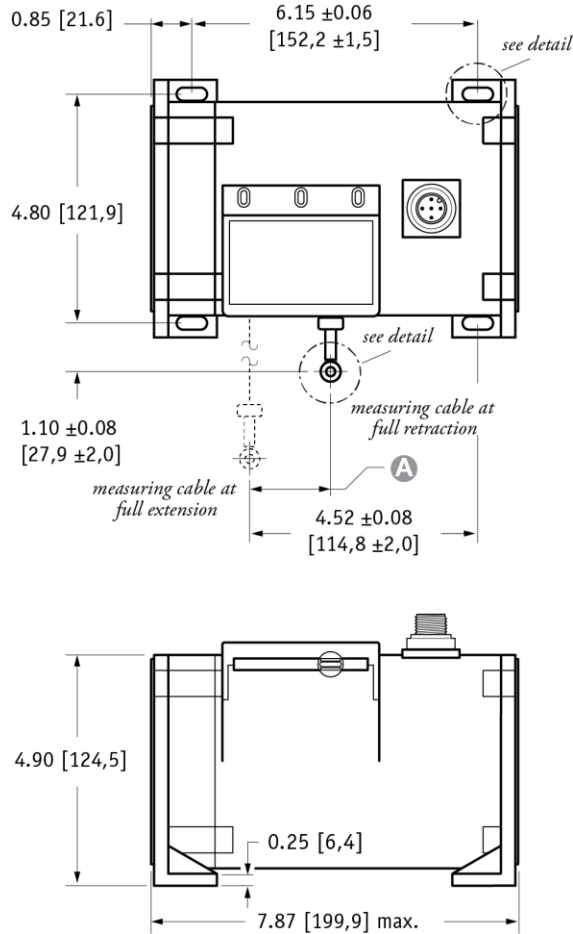

DIMENSIONS ARE IN INCHES [MM]  
tolerances are 0.03 IN. [0.5 MM] unless otherwise noted.

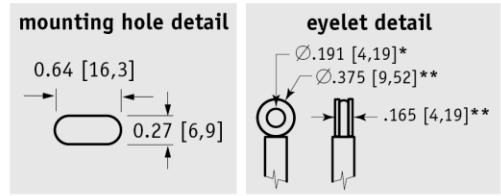

**A DIMENSION (INCHES)**

RANGE	MEASURING CABLE			
	Ø.031 in.	Ø.034 in.	Ø.047 in.	Ø.062 in.
75	n/a	0.22	0.29	0.37
100	n/a	0.29	0.39	0.49
150	n/a	0.44	0.59	0.73
200	n/a	0.58	0.79	0.98
250	n/a	0.73	0.98	1.22
300	n/a	0.88	1.18	1.47
350	n/a	1.02	1.38	1.71
400	n/a	1.17	1.57	1.96
450	n/a	1.31	1.77	n/a
500	n/a	1.46	1.97	n/a
550	1.61	1.61	n/a	n/a

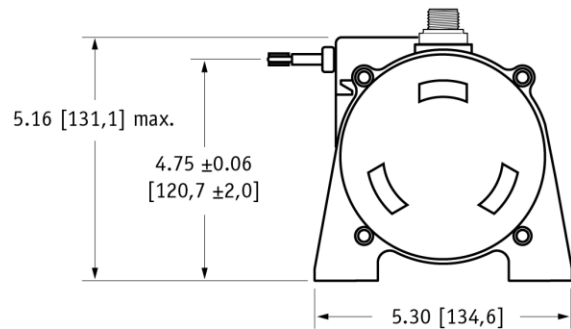

\* tolerance = +.005 -.001 [+.13 -.03]  
\*\* tolerance = +.005 -.005 [+.13 -.13]

**Ordering Information**

**Model Number:**

**PT9DN** -                                          
order code:    **R**    **A**    **B**    **C**    **D**    **E**    **F**    **G**

Sample Model Number:

**PT9DN - 200ALN3426FR - 500TRSC5**

- R** range: 200 (200 inches)
- A** enclosure: AL (aluminum)
- B** measuring cable: N34 (.034 nylon-coated stainless)
- C** measuring cable tension: 26 (26 oz.)
- D** cable exit: FR (front)
- E** baud rate: 500 (500k bits/sec.)
- F** terminating resistor: TR (with terminating resistor)
- G** electrical connection: SC5 (5-meter cordset with straight plug)

**Full Stroke Range:**

<b>R</b> order code:	75	100	150	200	250	300	350	400	450*	500*	550*
full stroke range, min:	75 in.	100 in.	150 in.	200 in.	250 in.	300 in.	350 in.	400 in.	450 in.	500 in.	550 in.

\* - 36 oz. cable tension strongly recommended

**Enclosure Material:**

<b>A</b> order code:	AL	SS
	powder-painted aluminum	303 stainless

# PT9DN

Heavy Industrial • DeviceNET®

## Measuring Cable:

<b>B</b> order code:	<b>N34</b>	<b>S47</b>	<b>S31</b>	<b>V62</b>
cable construction:	Ø.034-inch nylon-coated stainless steel rope	Ø.047-inch bare stainless steel rope	Ø.031-inch bare stainless steel rope	Ø.058-inch PVC jacketed vectra fiber rope
available ranges:	<i>all ranges</i>	<i>all ranges up to 500 inches</i>	<i>550 inch range only</i>	<i>all ranges up to 400 inches</i>
general use:	indoor	outdoor, debris, high temperature	outdoor, debris, high temperature	high voltage or magnetic field

## Measuring Cable Tension:

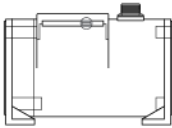
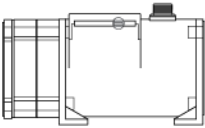
<b>C</b> order code:	<b>26</b>		<b>52</b>	
tension (30%):	18 oz.		36 oz.	
enclosure material:	<i>aluminum</i>	<i>stainless steel</i>	<i>aluminum</i>	<i>stainless steel</i>
max. acceleration:	1 g		5 g	
max. velocity:	60 inches/sec		200 inches/sec	
		standard housing <i>see fig 1.</i>		dual-spring housing <i>see fig 2.</i>

## Cable Exit:

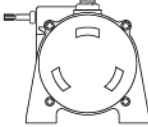
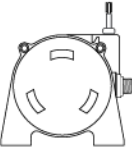
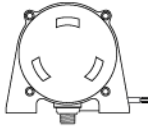
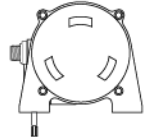
<b>D</b> order code:	<b>FR</b> front	<b>UP</b> top	<b>BK</b> back	<b>DN</b> down
				

## Baud Rate:

<b>F</b> order code:	<b>125</b>	<b>250</b>	<b>500</b>
	125 kbaud	250 kbaud	500 kbaud

## Terminating Resistor:

<b>F</b> order code:	<b>TR</b>	<b>NR</b>
	terminating resistor	no terminating resistor

## Electrical Connection:

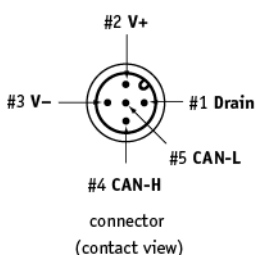
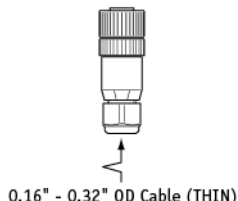
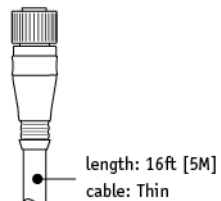
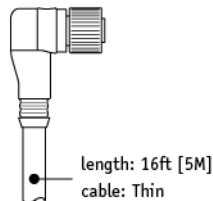
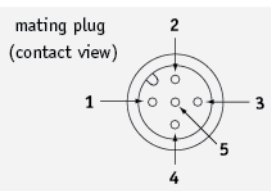
<b>G</b> order code:	<b>blank</b>	<b>MC5</b>	<b>SC5</b>	<b>NC5</b>																		
	5-pin micro-connector <i>(no mating plug supplied)</i>	5-pin micro-connector w/ mating plug	5-pin micro-connector and 5 meter length cordset w/straight mating plug	5-pin micro-connector and 5 meter length cordset w/90° mating plug																		
																						
		0.16" - 0.32" OD Cable (THIN)	length: 16ft [5M] cable: Thin	length: 16ft [5M] cable: Thin																		
		<table border="1"> <thead> <tr> <th>pin</th> <th>signal</th> <th>wire color</th> </tr> </thead> <tbody> <tr> <td>1</td> <td>drain</td> <td>brown</td> </tr> <tr> <td>2</td> <td>V+</td> <td>white</td> </tr> <tr> <td>3</td> <td>V-</td> <td>blue</td> </tr> <tr> <td>4</td> <td>Can-H</td> <td>black</td> </tr> <tr> <td>5</td> <td>Can-L</td> <td>grey</td> </tr> </tbody> </table>			pin	signal	wire color	1	drain	brown	2	V+	white	3	V-	blue	4	Can-H	black	5	Can-L	grey
pin	signal	wire color																				
1	drain	brown																				
2	V+	white																				
3	V-	blue																				
4	Can-H	black																				
5	Can-L	grey																				
																						

**Fig. 2 – Outline Drawing (36 oz. cable tension only)**

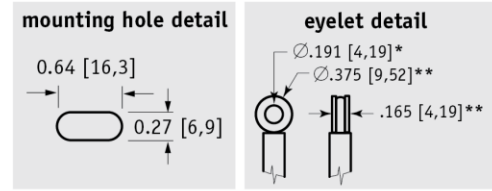
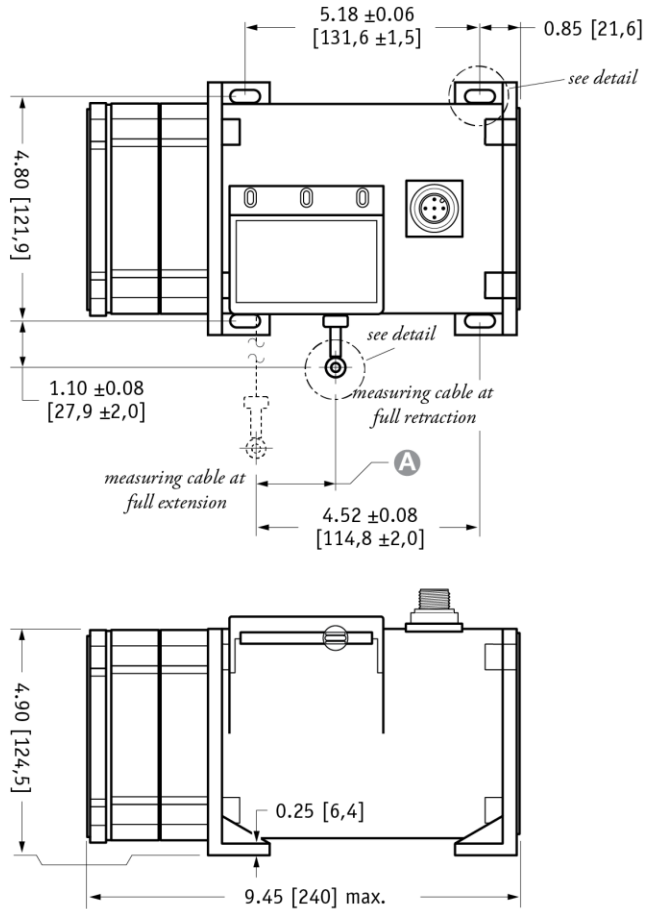

**A DIMENSION (INCHES)**

RANGE	MEASURING CABLE			
	Ø.031 in.	Ø.034 in.	Ø.047 in.	Ø.062 in.
75	n/a	0.22	0.29	0.37
100	n/a	0.29	0.39	0.49
150	n/a	0.44	0.59	0.73
200	n/a	0.58	0.79	0.98
250	n/a	0.73	0.98	1.22
300	n/a	0.88	1.18	1.47
350	n/a	1.02	1.38	1.71
400	n/a	1.17	1.57	1.96
450	n/a	1.31	1.77	n/a
500	n/a	1.46	1.97	n/a
550	1.61	1.61	n/a	n/a

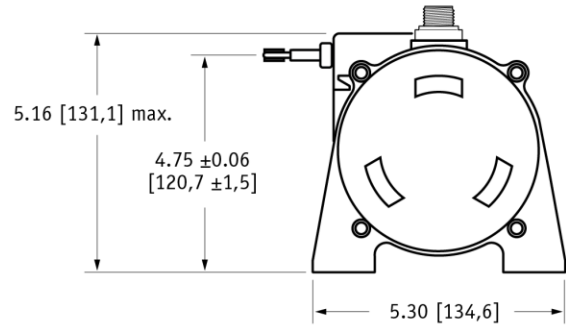

DIMENSIONS ARE IN INCHES [MM]  
tolerances are 0.03 IN. [0.5 MM] unless otherwise noted.

\* tolerance = +.005 -.001 [+.13 -.03]  
\*\* tolerance = +.005 -.005 [+.13 -.13]



**19 Waterman Ave. Toronto, Ont. M4B1Y2**  
**Tel: 416-445-5500 Fax: 416-445-1170**  
**Toll Free: 1-800-465-1600**  
**Email: sales@intertechnology.com**  
**Website: www.intertechnology.com**

[TE.com/sensorsolutions](http://TE.com/sensorsolutions)

Measurement Specialties, Inc., a TE Connectivity company.

Measurement Specialties, TE Connectivity, TE Connectivity (logo) and EVERY CONNECTION COUNTS are trademarks. All other logos, products and/or company names referred to herein might be trademarks of their respective owners.

The information given herein, including drawings, illustrations and schematics which are intended for illustration purposes only, is believed to be reliable. However, TE Connectivity makes no warranties as to its accuracy or completeness and disclaims any liability in connection with its use. TE Connectivity's obligations shall only be as set forth in TE Connectivity's Standard Terms and Conditions of Sale for this product and in no case will TE Connectivity be liable for any incidental, indirect or consequential damages arising out of the sale, resale, use or misuse of the product. Users of TE Connectivity products should make their own evaluation to determine the suitability of each such product for the specific application.

© 2015 TE Connectivity Ltd. family of companies All Rights Reserved.

PT9DN 12/01/2015