

With its incremental optical encoder and industrial design this rugged transducer provides the highest accuracy and longest life of any measurement device of its kind. This model is available in a wide variety of resolutions and output stages to fit virtually any requirement.

It can measure up to 550", yet when its cable is retracted it is only 6" long. Its small size and low-cost-to-measurement ratio offers remarkable flexibility and value.

Output Signal

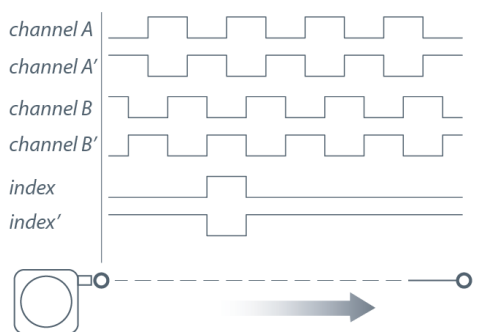

-- see ordering information for available channels

PT9150

Cable Actuated Sensor Heavy Industrial • Incremental Encoder

Linear Position to 550 inches (1400 cm)

Aluminum or Stainless Steel Enclosure Options

VLS Option to Prevent Free-Release Damage

IP67 • NEMA 6 Protection

General

Full Stroke Range	0-75 to 0-550 inches
Output Signal	incremental encoder (quadrature)
Accuracy	0.04% full stroke
Repeatability	± 0.02% full stroke ±1/2 pulse max.
Resolution	10 to 250 pulses per inch
Enclosure Material Options	powder-painted aluminum or 303 stainless steel
Sensor	optical incremental encoder
Potentiometer Cycle Life	
Maximum Retraction	see ordering information
Acceleration	
Maximum Velocity	see ordering information
Weight, Aluminum (Stainless Steel) Enclosure	8 lbs. (16 lbs.) max.

Electrical

Input Voltage	see ordering information
Input Current	see ordering information

Environmental

Enclosure	NEMA 4/4X/6, IP 67
Operating Temperature	0° to 160°F (-17° to 71°C)
Vibration	up to 10 g to 2000 Hz maximum

PT9150

Heavy Industrial • Incremental Encoder

Fig. 1 – Outline Drawing (18 oz. cable tension only)

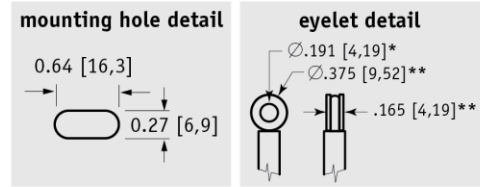
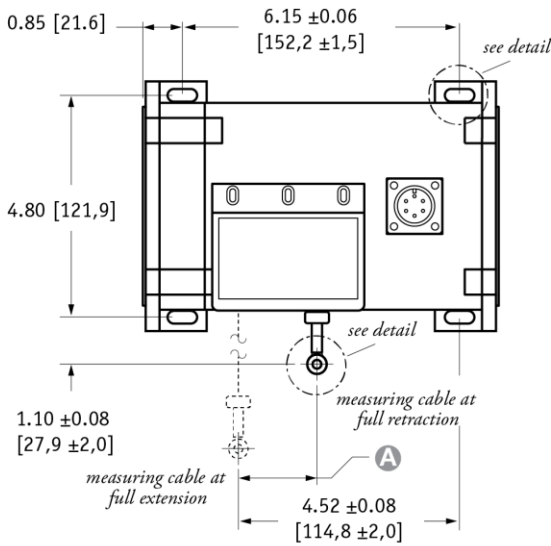

A DIMENSION (INCHES)

RANGE	MEASURING CABLE			
	Ø.031 in.	Ø.034 in.	Ø.047 in.	Ø.062 in.
75	n/a	0.22	0.29	0.37
100	n/a	0.29	0.39	0.49
150	n/a	0.44	0.59	0.73
200	n/a	0.58	0.79	0.98
250	n/a	0.73	0.98	1.22
300	n/a	0.88	1.18	1.47
350	n/a	1.02	1.38	1.71
400	n/a	1.17	1.57	1.96
450	n/a	1.31	1.77	n/a
500	n/a	1.46	1.97	n/a
550	1.61	1.61	n/a	n/a

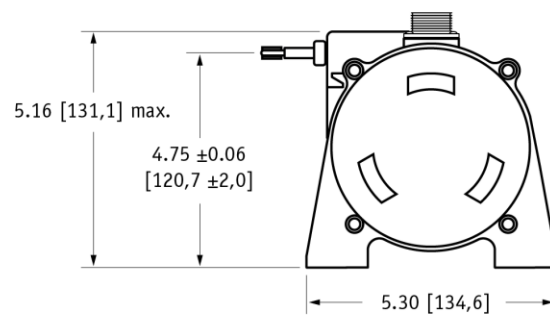
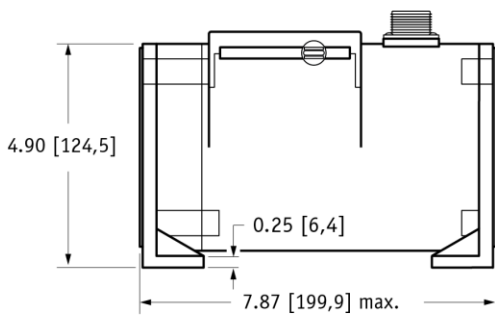

DIMENSIONS ARE IN INCHES [MM]
tolerances are 0.03 IN. [0.5 MM] unless otherwise noted.

* tolerance = +.005 -.001 [+.13 -.03]
** tolerance = +.005 -.005 [+ .13 -.13]

Ordering Information

Model Number:

PT9150- _____ **0**
order code: **R** **A** **B** **C** **D** **E** **F** **C**

Sample Model Number:

PT9150 - 0500 - 111 - 1110

- R** range: 500 inches
- A** enclosure/cable tension: aluminum/18 oz.
- B** measuring cable: .034 nylon-coated stainless
- C** cable exit: front
- D** output signal: TTL/CMOS driver
- E** resolution: 100 ±2 pulses per inch
- F** electrical connection: 6-pin plastic connector

Full Stroke Range:

R order code:	0075	0100	0150	0200	0250	0300	0350	0400	0450*	0500*	0550*
full stroke range, min:	75 in.	100 in.	150 in.	200 in.	250 in.	300 in.	350 in.	400 in.	450 in.	500 in.	550 in.

english ranges

R order code:	2500	3750	5000	6250	7500	8750	10000	11250	12500*	13750*
full stroke range, min:	2500 mm	3750 mm	5000 mm	6250 mm	7500 mm	8750 mm	10000 mm	11250 mm	12500 mm	13750 mm

metric ranges

* - 36 oz. cable tension strongly recommended

Enclosure Material and Measuring Cable Tension:

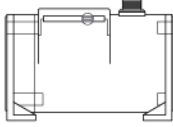
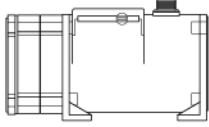
A order code:	1	3	2	4
tension ($\pm 30\%$):	18 oz.		36 oz.	
enclosure material:	<i>powder-painted aluminum</i>	<i>303 stainless steel</i>	<i>powder-painted aluminum</i>	<i>303 stainless steel</i>
max. acceleration:	1 g	1 g	5 g	5 g
max. velocity:	60 inches/sec	60 inches/sec	200 inches/sec	200 inches/sec
		standard housing see fig 1.		dual-spring housing see fig 2.

Measuring Cable:

B order code:	1	2	3	4
cable construction:	\varnothing .034-inch nylon-coated stainless steel rope	\varnothing .047-inch bare stainless steel rope	\varnothing .058-inch PVC jacketed vectra fiber rope	\varnothing .031-inch bare stainless steel rope
available ranges:	<i>all ranges</i>	<i>all ranges up to 500 inches</i>	<i>all ranges up to 400 inches</i>	<i>550-inch range only</i>
general use:	indoor	outdoor, debris, high temperature	high voltage or magnetic field	outdoor, debris, high temperature

Cable Exit:

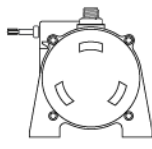
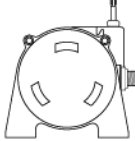
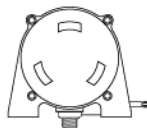
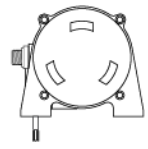
C order code:	1	2	3	4
	front	top	back	down
				

Output Signals:

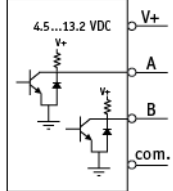
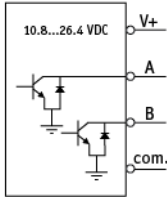
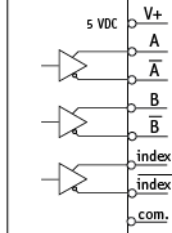
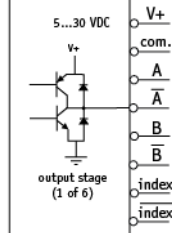
D order code:	1	2	3	4
output driver:	TTL - CMOS	Open Collector	5 V - Line Driver	Universal Line Driver
Input voltage (V+):	4.5...13.2 Vdc	10.8...26.4 Vdc	5 Vdc	5...28 VDC
Sink current:	20 mA max.	20 mA max.	20 mA max.	20 mA max.
Input current:	80 mA max.	80 mA max.	150 mA max.	100 mA max, no load
				

Resolution:

E order code:	1	2	3	4
english ranges:	100 \pm 2 pulses per in.	200 \pm 4 pulses per in.	250 \pm 5 pulses per in.	10 \pm 0.2 pulses per in.
metric ranges:	5 \pm 0,1 pulses per mm	10 \pm 0,2 pulses per mm	12,5 \pm 0,25 pulses per mm	0,5 \pm 0,01 pulses per mm

PT9150

Heavy Industrial • Incremental Encoder

Electrical Connection:

Order code:

1		2		3		4																																																																										
6-pin plastic connector with mating plug IP 67, NEMA 4X*,6		25-ft. instrumentation cable 24 AWG, shielded IP 67, NEMA 6		18-pin plastic connector with mating plug IP 65, NEMA 4		6-pin metal connector with mating plug IP 67, NEMA 6																																																																										
.30 - .39 in. [8 - 10 mm] cable dia. 16 AWG max conductor size connector: MS3102E-14S-6P mating plug: MS3106E-14S-6S		25 ft. x 0.2-in. dia. [7,5 M x 5 mm dia.] 24 AWG, shielded		.26 - .30 in. [6,6 - 7,6 mm] cable dia. 20 - 24 AWG conductor size connector: Conxall 14282-18PG-300-K mating plug: Conxall 13282-18SG-326-K		3/8-in. [9 mm] max cable dia. 16 AWG max conductor size connector: MS3102E-14S-6P mating plug: MS3106E-14S-6S																																																																										
6-pin mating plug: <table border="1"> <thead> <tr> <th>pin</th> <th>TTL/CMOS Open Collector input voltage</th> <th>5 V Line Driver Universal Line Driver input voltage</th> </tr> </thead> <tbody> <tr><td>A</td><td>common</td><td>channel A</td></tr> <tr><td>B</td><td>channel A</td><td>channel B</td></tr> <tr><td>C</td><td>channel B</td><td>-</td></tr> <tr><td>D</td><td>-</td><td>channel A'</td></tr> <tr><td>E</td><td>-</td><td>channel B'</td></tr> <tr><td>F</td><td>-</td><td>-</td></tr> </tbody> </table>		pin	TTL/CMOS Open Collector input voltage	5 V Line Driver Universal Line Driver input voltage	A	common	channel A	B	channel A	channel B	C	channel B	-	D	-	channel A'	E	-	channel B'	F	-	-	18-pin mating plug: <table border="1"> <thead> <tr> <th>pin</th> <th>TTL/CMOS Open Collector input voltage</th> <th>5 V Line Driver Universal Line Driver input voltage</th> </tr> </thead> <tbody> <tr><td>1</td><td>common</td><td>channel B</td></tr> <tr><td>2</td><td>channel B</td><td>channel A</td></tr> <tr><td>3</td><td>channel A</td><td>index</td></tr> <tr><td>6</td><td>-</td><td>channel B'</td></tr> <tr><td>7</td><td>-</td><td>channel A'</td></tr> <tr><td>11</td><td>-</td><td>index'</td></tr> <tr><td>12</td><td>-</td><td>-</td></tr> <tr><td>15</td><td>-</td><td>-</td></tr> </tbody> </table>		pin	TTL/CMOS Open Collector input voltage	5 V Line Driver Universal Line Driver input voltage	1	common	channel B	2	channel B	channel A	3	channel A	index	6	-	channel B'	7	-	channel A'	11	-	index'	12	-	-	15	-	-	25-ft. instrumentation cable: <table border="1"> <thead> <tr> <th>color</th> <th>TTL/CMOS Open Collector input voltage</th> <th>5 V Line Driver Universal Line Driver input voltage</th> </tr> </thead> <tbody> <tr><td>red</td><td>common</td><td>channel A</td></tr> <tr><td>black</td><td>channel A</td><td>channel B</td></tr> <tr><td>green</td><td>channel B</td><td>-</td></tr> <tr><td>white</td><td>-</td><td>channel A'</td></tr> <tr><td>blue</td><td>-</td><td>channel B'</td></tr> <tr><td>brown</td><td>-</td><td>index</td></tr> <tr><td>yellow</td><td>-</td><td>index'</td></tr> <tr><td>orange</td><td>-</td><td>-</td></tr> </tbody> </table>		color	TTL/CMOS Open Collector input voltage	5 V Line Driver Universal Line Driver input voltage	red	common	channel A	black	channel A	channel B	green	channel B	-	white	-	channel A'	blue	-	channel B'	brown	-	index	yellow	-	index'	orange	-	-
pin	TTL/CMOS Open Collector input voltage	5 V Line Driver Universal Line Driver input voltage																																																																														
A	common	channel A																																																																														
B	channel A	channel B																																																																														
C	channel B	-																																																																														
D	-	channel A'																																																																														
E	-	channel B'																																																																														
F	-	-																																																																														
pin	TTL/CMOS Open Collector input voltage	5 V Line Driver Universal Line Driver input voltage																																																																														
1	common	channel B																																																																														
2	channel B	channel A																																																																														
3	channel A	index																																																																														
6	-	channel B'																																																																														
7	-	channel A'																																																																														
11	-	index'																																																																														
12	-	-																																																																														
15	-	-																																																																														
color	TTL/CMOS Open Collector input voltage	5 V Line Driver Universal Line Driver input voltage																																																																														
red	common	channel A																																																																														
black	channel A	channel B																																																																														
green	channel B	-																																																																														
white	-	channel A'																																																																														
blue	-	channel B'																																																																														
brown	-	index																																																																														
yellow	-	index'																																																																														
orange	-	-																																																																														

* -applies to stainless steel enclosure only.

VLS Option - Free Release Protection

The patented Celesco Velocity Limiting System (VLS) is an option for PT9000 Series cable extension transducers that limits cable retraction to a safe 40 to 55 inches per second for the single spring option and 40 to 80 inches per second for the higher tension dual spring option.

The VLS option prevents the measuring cable from ever reaching a damaging velocity during an accidental free release. This option is ideal for mobile applications that require frequent cable disconnection and reconnection. It prevents expensive unscheduled downtime due to accidental cable mishandling or attachment failure.

- using guide below, select PT9150 model **PT9150-0100-111-1110**
- remove "PT" from the model number ~~PT~~ **9150-0100-111-1110**
- add "VLS"
VLS + 9150-0100-111-1110
- completed model number!
VLS9150-0100-111-1110

VLS9150 - A B C D E F **0**

<i>english ranges</i>	0075	1	1	1	1	1	1
	to	2	2	2	2	2	2
<i>metric ranges</i>	0550	3	3	3	3	3	3
	to	4	4	4	4	4	4
	02500						
	to						
	13750						

 = available options.

Fig. 2 – Outline Drawing (36 oz. cable tension only)

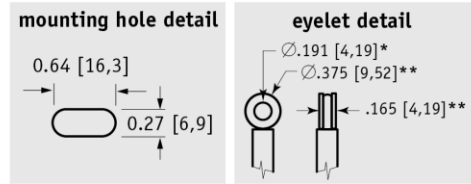
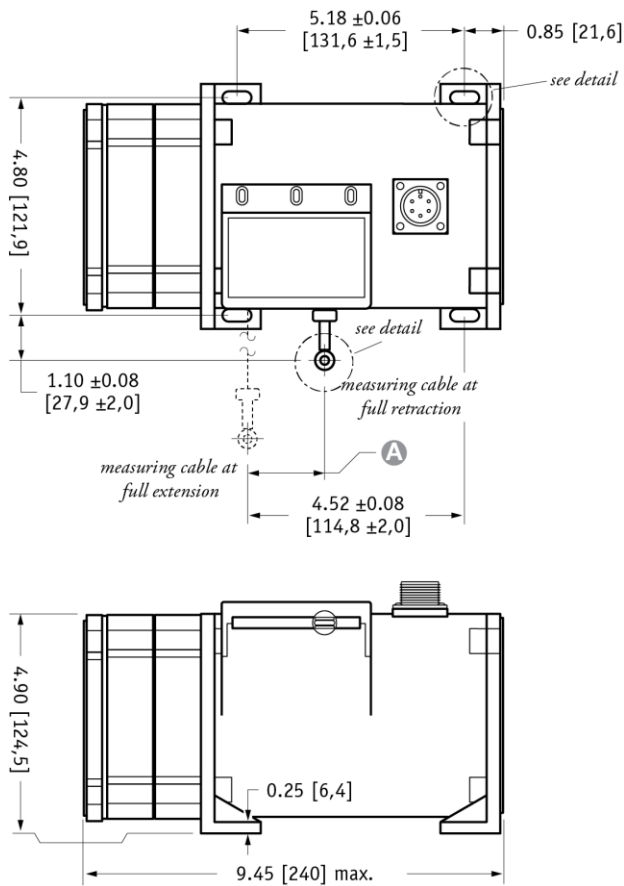

A DIMENSION (INCHES)

RANGE	MEASURING CABLE			
	∅.031 in.	∅.034 in.	∅.047 in.	∅.062 in.
75	n/a	0.22	0.29	0.37
100	n/a	0.29	0.39	0.49
150	n/a	0.44	0.59	0.73
200	n/a	0.58	0.79	0.98
250	n/a	0.73	0.98	1.22
300	n/a	0.88	1.18	1.47
350	n/a	1.02	1.38	1.71
400	n/a	1.17	1.57	1.96
450	n/a	1.31	1.77	n/a
500	n/a	1.46	1.97	n/a
550	1.61	1.61	n/a	n/a

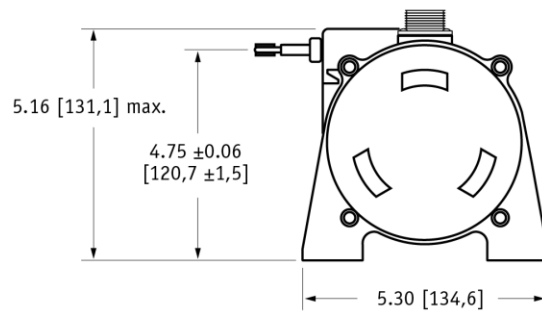

DIMENSIONS ARE IN INCHES [MM]
tolerances are 0.03 IN. [0.5 MM] unless otherwise noted.

* tolerance = +.005 -.001 [+13 -.03]
** tolerance = +.005 -.005 [+13 -.13]



19 Waterman Ave. Toronto, Ont. M4B1Y2
Tel: 416-445-5500 Fax: 416-445-1170
Toll Free: 1-800-465-1600
Email: sales@intertechnology.com
Website: www.intertechnology.com

TE.com/sensorsolutions

Measurement Specialties, Inc., a TE Connectivity company.

Measurement Specialties, TE Connectivity, TE Connectivity (logo) and EVERY CONNECTION COUNTS are trademarks. All other logos, products and/or company names referred to herein might be trademarks of their respective owners.

The information given herein, including drawings, illustrations and schematics which are intended for illustration purposes only, is believed to be reliable. However, TE Connectivity makes no warranties as to its accuracy or completeness and disclaims any liability in connection with its use. TE Connectivity's obligations shall only be as set forth in TE Connectivity's Standard Terms and Conditions of Sale for this product and in no case will TE Connectivity be liable for any incidental, indirect or consequential damages arising out of the sale, resale, use or misuse of the product. Users of TE Connectivity products should make their own evaluation to determine the suitability of each such product for the specific application.

© 2015 TE Connectivity Ltd. family of companies All Rights Reserved.

PT9150 12/01/2015