

The PT9101 is a work-horse for demanding long-range applications requiring a linear position measurements in ranges up to 1700 inches. Available with either a 500, 1K, 5K, or 10K ohm potentiometer, the PT9101 operates with any basic panel meter or programmable controller.

As a member of our innovative family of NEMA 4 rated cable-extension transducers, the PT9101 offers numerous benefits. It installs in minutes, works without perfect parallel alignment, and when its stainless-steel cable is retracted, it measures only 6".

### Output Signal

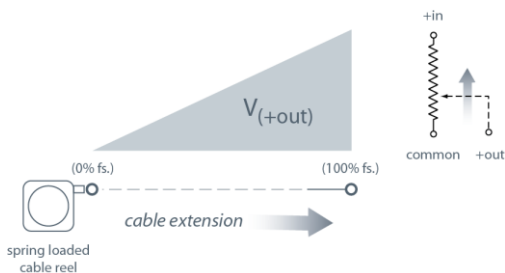

— bridge circuit option available, see ordering information

## PT9101

### Cable Actuated Sensor Heavy Industrial • Voltage Divider

**Absolute Linear Position to 550 inches (1400 cm)**

**Aluminum or Stainless Steel Enclosure Options**

**VLS Option to Prevent Free-Release Damage**

**IP68 • NEMA 6 Protection**

#### General

<b>Full Stroke Range</b>	0-75 to 0-550 inches
<b>Output Signal</b>	voltage divider (potentiometer)
<b>Accuracy</b>	± 0.10% full stroke
<b>Repeatability</b>	± 0.02% full stroke
<b>Resolution</b>	essentially infinite
<b>Enclosure Material Options</b>	stainless steel or thermoplastic
<b>Sensor</b>	plastic-hybrid precision potentiometer
<b>Potentiometer Cycle Life</b>	≥ 250,000
<b>Maximum Retraction</b>	see ordering information
<b>Acceleration</b>	
<b>Maximum Velocity</b>	see ordering information
<b>Weight, Aluminum (Stainless Steel) Enclosure</b>	8 lbs. (16 lbs.) max.

#### Electrical

<b>Input Resistance Options</b>	500, 1K, 5K, 10K Ω, bridge
<b>Power Rating, Watt</b>	2.0 at 70°F derated to 0 at 250° F
<b>Recommended Maximum Input Voltage</b>	30V (AC/DC)
<b>Output Signal Change Over Full Stroke Range</b>	94% ±4% of input voltage

#### Environmental

<b>Enclosure</b>	NEMA 4/4X/6, IP 67/68
<b>Operating Temperature</b>	-40° to 200°F (-40° to 90°C)
<b>Vibration</b>	up to 10 g to 2000 Hz maximum

**PT9101**

Heavy Industrial • Voltage Divider

Fig. 1 – Outline Drawing (18 oz. cable tension only)

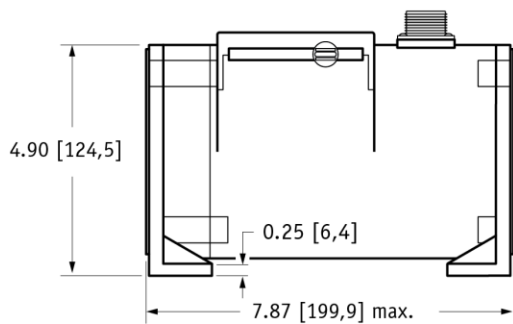
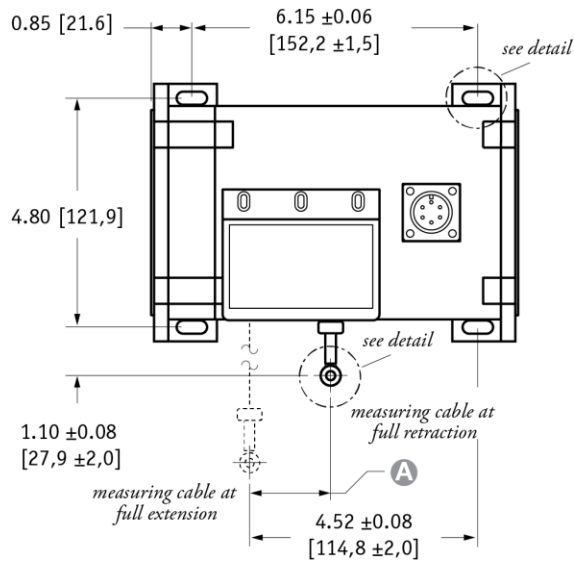

DIMENSIONS ARE IN INCHES [MM]  
tolerances are 0.03 IN. [0.5 MM] unless otherwise noted.

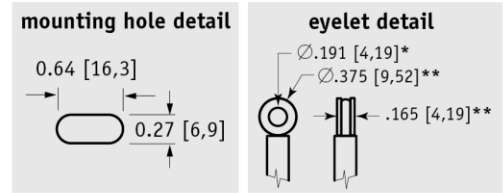

**A DIMENSION (INCHES)**

RANGE	MEASURING CABLE			
	Ø.031 in.	Ø.034 in.	Ø.047 in.	Ø.062 in.
75	n/a	0.22	0.29	0.37
100	n/a	0.29	0.39	0.49
150	n/a	0.44	0.59	0.73
200	n/a	0.58	0.79	0.98
250	n/a	0.73	0.98	1.22
300	n/a	0.88	1.18	1.47
350	n/a	1.02	1.38	1.71
400	n/a	1.17	1.57	1.96
450	n/a	1.31	1.77	n/a
500	n/a	1.46	1.97	n/a
550	1.61	1.61	n/a	n/a

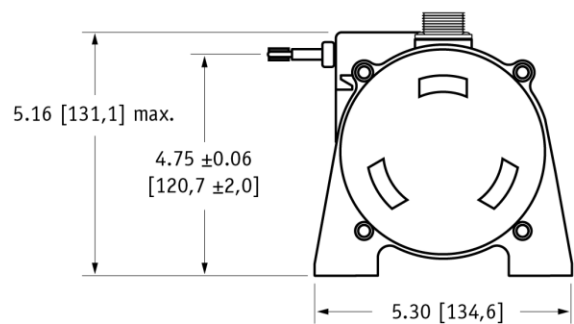

\* tolerance = +.005 -.001 [+ .13 -.03]  
\*\* tolerance = +.005 -.005 [+ .13 -.13]

**Ordering Information**

**Model Number:**

**PT9101** -      -      -      -      -      -      -      -       
order code:            R            A            B            C            D            E            F            C

**Sample Model Number:**

**PT9101 - 0500 - 111 - 1110**

- R** range: 500 inches
- A** enclosure/cable tension: aluminum/18 oz.
- B** measuring cable: .034 nylon-coated stainless
- C** cable exit: front
- D** output signal: 500 ohm potentiometer
- F** electrical connection: 6-pin plastic connector

**Full Stroke Range:**

**R order code:** **0075**   **0100**   **0150**   **0200**   **0250**   **0300**   **0350**   **0400**   **0450\***   **0500\***   **0550\***  
 full stroke range, min: 75 in.   100 in.   150 in.   200 in.   250 in.   300 in.   350 in.   400 in.   450 in.   500 in.   550 in.

\* - 36 oz. cable tension strongly recommended

# PT9101

Heavy Industrial • Voltage Divider

## Enclosure Material and Measuring Cable Tension:

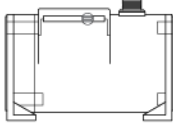
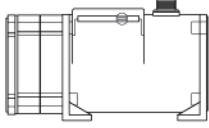
A order code:	1	3	2	4
tension ( $\pm 30\%$ ):	18 oz.		36 oz.	
enclosure material:	<i>powder-painted aluminum</i>	<i>303 stainless steel</i>	<i>powder-painted aluminum</i>	<i>303 stainless steel</i>
max. acceleration:	1 g	1 g	5 g	5 g
max. velocity:	60 inches/sec	60 inches/sec	200 inches/sec	200 inches/sec
		standard housing see fig 1.		dual-spring housing see fig 2.

## Measuring Cable:

B order code:	1	2	3	4
cable construction:	$\varnothing$ .034-inch nylon-coated stainless steel rope	$\varnothing$ .047-inch bare stainless steel rope	$\varnothing$ .058-inch PVC jacketed vectra fiber rope	$\varnothing$ .031-inch bare stainless steel rope
available ranges:	<i>all ranges</i>	<i>all ranges up to 500 inches</i>	<i>all ranges up to 400 inches</i>	<i>550-inch range only</i>
general use:	indoor	outdoor, debris, high temperature	high voltage or magnetic field	outdoor, debris, high temperature

## Cable Exit:

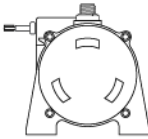
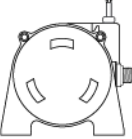
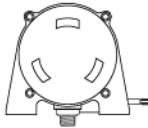
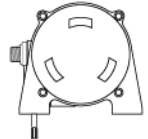
C order code:	front	top	back	down
				

## Output Signals:

D order code:	1	2	3	4	5	6
	500 ohm*	1000 ohm*	5000 ohm*	10,000 ohm*	fixed bridge (2 mV/V)	adjustable bridge (0...30 mV/V)
				*tolerance = $\pm 10\%$		

circuit, options 1-4

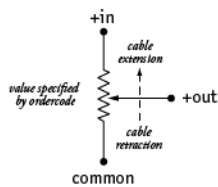

fixed bridge circuit

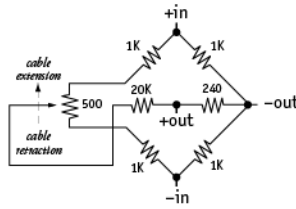

full scale output: 2 mV/V  
zero adjust: not available

adjustable bridge circuit

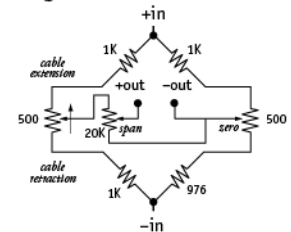



full scale output: adjustable from 0 to 30mV/V  
zero adjust: to 50% of full stroke

# PT9101

Heavy Industrial • Voltage Divider

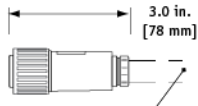
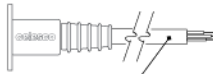
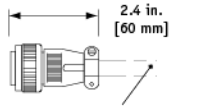
## Electrical Connection:

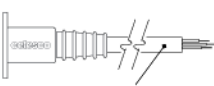
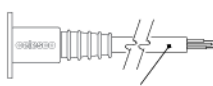
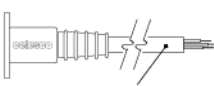
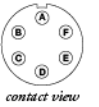
<p><b>order code:</b> <b>1</b></p> <p>6-pin plastic connector w/mating plug <b>IP 67, NEMA 4X**, 6</b></p>  <p>3.0 in. [78 mm]</p> <p>1/2 - 5/16" [14 - 8 mm] cable dia. 16 AWG max conductor size connector: MS3102E-145-6P mating plug: MS3106E-145-6S</p>	<p><b>2</b></p> <p>10-ft. [3 M] waterproof cable <b>IP 67, NEMA 4X**, 6</b></p>  <p>10 ft. x 0.4-in. dia. [3 M x 10 mm dia.] 18 AWG, type SJTOW</p>	<p><b>3</b></p> <p>6-pin metal connector w/mating plug <b>IP 65, NEMA 4</b></p>  <p>2.4 in. [60 mm]</p> <p>3/8-in. [9 mm] max cable dia. 16 AWG max conductor size connector: MS3102E-145-6P mating plug: MS3106E-145-6S</p>	<p><b>4</b></p> <p>25-ft. [7.5 M] instrumentation cable <b>IP 67, NEMA 6</b></p>  <p>25 ft. x 0.2-in. dia. [7.5 M x 5 mm dia.] 24 AWG, shielded</p>																																												
<p><b>order code:</b> <b>5</b></p> <p>100-ft. [30 M] waterproof cable <b>IP 67, NEMA 4X**, 6</b></p>  <p>100 ft. x 0.4-in. dia. [30 M x 10 mm dia.] 18 AWG, type SJTOW</p>	<p><b>6</b></p> <p>10-ft. [3 M] <b>pressure tested*</b> waterproof cable <b>IP 68, NEMA 4X**, 6P</b></p>  <p>10 ft. x 0.4-in. dia. [3 M x 10 mm dia.] 18 AWG, type SJTOW</p>	<p><b>7</b></p> <p>100-ft. [30 M] <b>pressure tested*</b> waterproof cable <b>IP 68, NEMA 4X**, 6P</b></p>  <p>100 ft. x 0.4-in. dia. [30 M x 10 mm dia.] 18 AWG, type SJTOW</p>																																													
<p><b>6-pin Mating Plug</b></p> <table border="1"> <tr> <th>pin</th> <th>standard</th> <th>bridge</th> </tr> <tr> <td>A</td> <td>+ in</td> <td>+ in</td> </tr> <tr> <td>B</td> <td>common</td> <td>- in</td> </tr> <tr> <td>C</td> <td>+ out</td> <td>- out</td> </tr> <tr> <td>D</td> <td>-</td> <td>+ out</td> </tr> </table>  <p>contact view</p>		pin	standard	bridge	A	+ in	+ in	B	common	- in	C	+ out	- out	D	-	+ out	<p><b>Waterproof Cable</b></p> <table border="1"> <tr> <th>color code</th> <th>standard</th> <th>bridge</th> </tr> <tr> <td>WHITE</td> <td>+ in</td> <td>n/a</td> </tr> <tr> <td>BLACK</td> <td>common</td> <td>n/a</td> </tr> <tr> <td>GREEN</td> <td>+ out</td> <td>n/a</td> </tr> </table>		color code	standard	bridge	WHITE	+ in	n/a	BLACK	common	n/a	GREEN	+ out	n/a	<p><b>Instrumentation Cable</b></p> <table border="1"> <tr> <th>color code</th> <th>standard</th> <th>bridge</th> </tr> <tr> <td>RED</td> <td>+ in</td> <td>+ in</td> </tr> <tr> <td>BLACK</td> <td>common</td> <td>- in</td> </tr> <tr> <td>GREEN</td> <td>+ out</td> <td>+ out</td> </tr> <tr> <td>WHITE</td> <td>-</td> <td>- out</td> </tr> </table>		color code	standard	bridge	RED	+ in	+ in	BLACK	common	- in	GREEN	+ out	+ out	WHITE	-	- out
pin	standard	bridge																																													
A	+ in	+ in																																													
B	common	- in																																													
C	+ out	- out																																													
D	-	+ out																																													
color code	standard	bridge																																													
WHITE	+ in	n/a																																													
BLACK	common	n/a																																													
GREEN	+ out	n/a																																													
color code	standard	bridge																																													
RED	+ in	+ in																																													
BLACK	common	- in																																													
GREEN	+ out	+ out																																													
WHITE	-	- out																																													

Notes: \* - Test pressure: 100 feet [30 meters] H<sub>2</sub>O (40 PSID); Test Medium: Air; Duration: 2 hours. \*\* - NEMA 4X applies to stainless steel enclosure only.

## VLS Option - Free Release Protection

The patented Celesco Velocity Limiting System (VLS) is an option for PT9000 Series cable extension transducers that limits cable retraction to a safe 40 to 55 inches per second for the single spring option and 40 to 80 inches per second for the higher tension dual spring option.

The VLS option prevents the measuring cable from ever reaching a damaging velocity during an accidental free release. This option is ideal for mobile applications that require frequent cable disconnection and reconnection. It prevents expensive unscheduled downtime due to accidental cable mishandling or attachment failure.

- using guide below, select PT9101 model **PT9101-0100-111-1110**
- remove "PT" from the model number ~~PT~~ **9101-0100-111-1110**
- add "VLS" **VLS + 9101-0100-111-1110**
- completed model number! **VLS9101-0100-111-1110**

**VLS9101** - 

	<b>0</b>	<b>A</b>	<b>B</b>	<b>C</b>	<b>D</b>	<b>1</b>	<b>E</b>	<b>F</b>	<b>0</b>
0075		1	1	1	1				1
thru		2	2	2	2				2
0550		3	3	3	3				3
		4	4	4	4				4
									5
									6
									7

□ = available options.

Fig. 2 – Outline Drawing (36 oz. cable tension only)

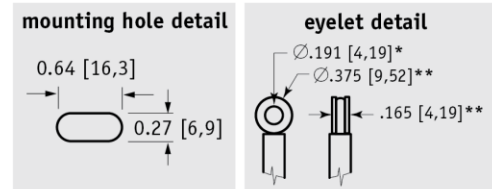
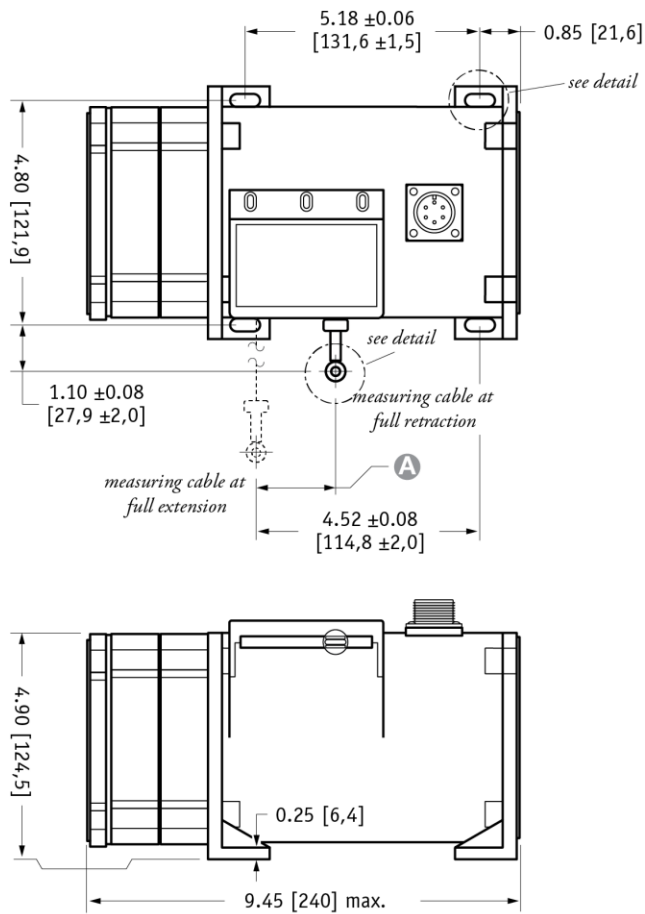

**A DIMENSION (INCHES)**

RANGE	MEASURING CABLE			
	Ø.031 in.	Ø.034 in.	Ø.047 in.	Ø.062 in.
75	n/a	0.22	0.29	0.37
100	n/a	0.29	0.39	0.49
150	n/a	0.44	0.59	0.73
200	n/a	0.58	0.79	0.98
250	n/a	0.73	0.98	1.22
300	n/a	0.88	1.18	1.47
350	n/a	1.02	1.38	1.71
400	n/a	1.17	1.57	1.96
450	n/a	1.31	1.77	n/a
500	n/a	1.46	1.97	n/a
550	1.61	1.61	n/a	n/a

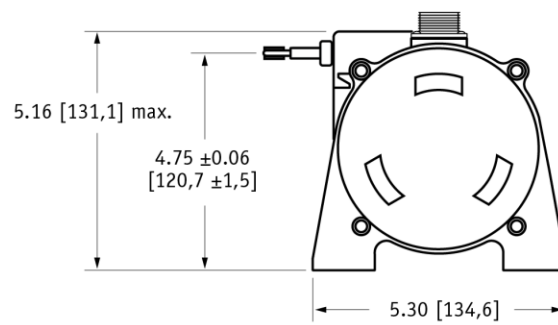

DIMENSIONS ARE IN INCHES [MM]  
tolerances are 0.03 IN. [0.5 MM] unless otherwise noted.

\* tolerance = +.005 -.001 [+.13 -.03]  
\*\* tolerance = +.005 -.005 [+ .13 -.13]



19 Waterman Ave. Toronto, Ont. M4B1Y2  
Tel: 416-445-5500 Fax: 416-445-1170  
Toll Free: 1-800-465-1600  
Email: sales@intertechnology.com  
Website: www.intertechnology.com

[TE.com/sensorsolutions](http://TE.com/sensorsolutions)

Measurement Specialties, Inc., a TE Connectivity company.

Measurement Specialties, TE Connectivity, TE Connectivity (logo) and EVERY CONNECTION COUNTS are trademarks. All other logos, products and/or company names referred to herein might be trademarks of their respective owners.

The information given herein, including drawings, illustrations and schematics which are intended for illustration purposes only, is believed to be reliable. However, TE Connectivity makes no warranties as to its accuracy or completeness and disclaims any liability in connection with its use. TE Connectivity's obligations shall only be as set forth in TE Connectivity's Standard Terms and Conditions of Sale for this product and in no case will TE Connectivity be liable for any incidental, indirect or consequential damages arising out of the sale, resale, use or misuse of the product. Users of TE Connectivity products should make their own evaluation to determine the suitability of each such product for the specific application.

© 2015 TE Connectivity Ltd. family of companies All Rights Reserved.

PT9101 12/01/2015