

The PT5MA potentiometric cable-extension transducer uses a unique thermoplastic cable that has virtually an infinite fatigue life. This cable, known as V62, has properties that are superior for high cycle and rugged applications.

Like Celesco's other transducers, the PT5MA installs in minutes, functions properly without perfectly parallel alignment, and fits easily into small areas. The PT5MA offers additional installation flexibility since its cable exit can be rotated relative to the mounting surface, providing four different cable exit orientations.

Output Signal

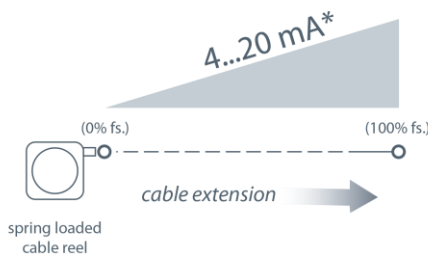

*Optional 3-wire, 0...20mA output signal available.

PT5MA

Cable Actuated Sensor Industrial Grade • 0...5, 0...10 Vdc

Absolute Linear Position to 250 inches (6350 mm)

Hard Anodized Aluminum Enclosure

High Cycle Applications

IP67 • NEMA 6 Protection

General

Full Stroke Range	0-10 to 0-250 inches
Options	
Output Signal Options	4...20 mA (2-wire) and 0...20 mA (3-wire)
Accuracy	± 0.75% to ±0.18% full stroke (see ordering information)
Repeatability	±0.02% to ±0.1% f.s. (see ordering information)
Resolution	essentially infinite
Measuring Cable	stainless steel or thermoplastic
Enclosure	hard anodized aluminum
Sensor	plastic-hybrid precision potentiometer
Potentiometer Cycle Life	see ordering information
Maximum Measuring Cable Velocity	see ordering information
Maximum Retraction Acceleration	see ordering information
Weight	5 lbs. max.

Electrical

Input	see ordering information
Input Current	20 mA max.
Maximum Loop Resistance (Load)	$(\text{loop supply voltage} - 8)/0.020$
Circuit Protection	38 mA max.
Impedance	100 M ohms @ 100 VDC, min.
Signal Adjust, Zero	from factory set zero to 50% of full stroke range
Signal Adjust, Span	to 50% of factory set span

Environmental

Enclosure	NEMA 4/6, IP 65/67
Operating Temperature	-40° to 200°F (-40° to 90°C)
Vibration	up to 10 g to 2000 Hz maximum

EMC COMPLIANCE PER DIRECTIVE 89/336/EEC

Emission/Immunity	EN50081-2 / EN50082-2
--------------------------	-----------------------

PT5MA

Industrial Grade • 0...5, 0...10 Vdc

Outline Drawing

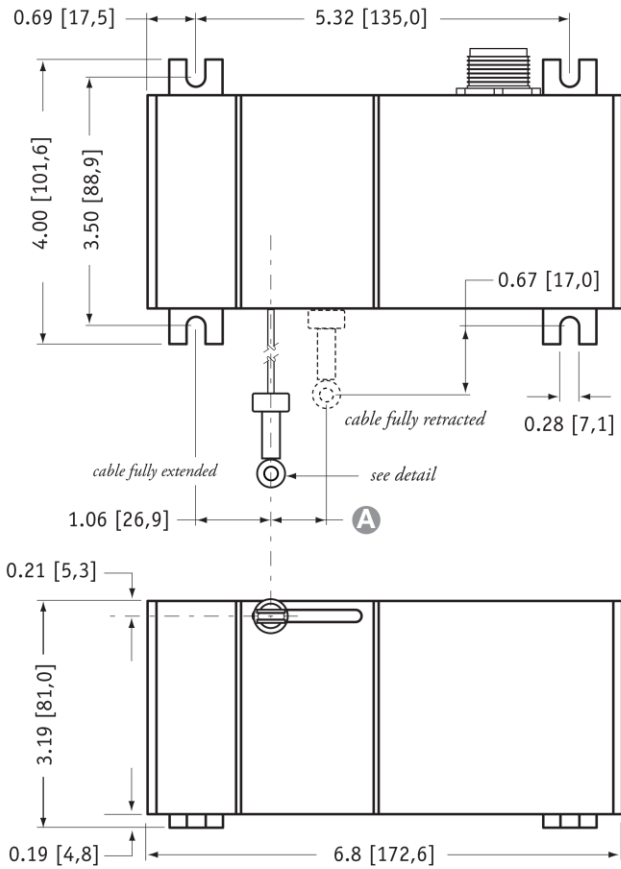

eyelet detail

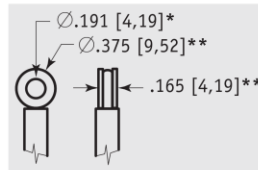

A DIMENSION (inches[mm])

RANGE	DIMENSION (inches[mm])	
	N34 measuring cable	S47 & V62 measuring cable
10	0.05 [1,2]	0.08 [2,0]
15	0.07 [1,8]	0.12 [3,0]
20	0.09 [2,4]	0.16 [3,9]
30	0.14 [3,5]	0.23 [5,9]
40	0.19 [4,7]	0.31 [7,9]
50	0.23 [5,9]	0.39 [9,9]
60	0.28 [7,0]	0.47 [11,8]
80	0.37 [9,4]	0.62 [15,8]
100	0.46 [11,7]	0.78 [19,7]
125	0.58 [14,7]	0.97 [24,7]
150	0.69 [17,6]	1.16 [29,6]
200	0.92 [23,5]	n/a
250	1.16 [29,3]	n/a

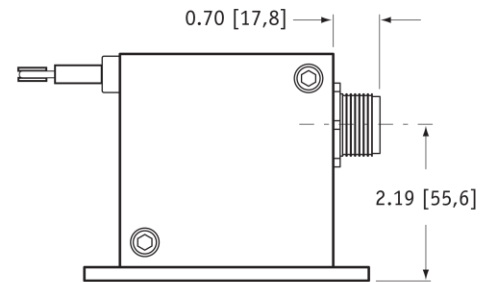

DIMENSIONS ARE IN INCHES [MM]
tolerances are 0.03 IN. [0.5 MM] unless otherwise noted.

* tolerance = +.005 - .001 [+13 - .03]
** tolerance = +.005 - .005 [+13 - 13]

Ordering Information

Model Number:

PT5MA - - - - -
order code: **R** **A** **B** **C** **D**

Sample Model Number:

PT5MA - 100 - N34 - FR - 420E - M6

- R** range: 100 inches
- A** measuring cable: .034 nylon-coated stainless
- B** cable exit: front
- C** output signal: 4...20 mA
- D** electrical connection: 6-pin plastic connector

Full Stroke Range:

R order code:	10	15	20	25	30	40	50	60	80	100	125	150	200	250
full stroke range, min:	10 in.	15 in.	20 in.	25 in.	30 in.	40 in.	50 in.	60 in.	80 in.	100 in.	125 in.	150 in.	200 in.	250 in.
accuracy (±% of f.s.):	.75%	.6%	.5%	.5%	.5%	.3%	.3%	.25%	.25%	.25%	.25%	.18%	.18%	.18%
repeatability (±% of f.s.):	.1%	.1%	.05%	.05%	.05%	.05%	.05%	.02%	.02%	.02%	.02%	.02%	.02%	.02%
potentiometer cycle life:	2,500,000 cycles						500,000 cycles						250,000 cycles	
cable tension (20%):	41 ounces						21 ounces							
max. cable velocity/acceleration:	300 in./sec • 5 g						120 in./sec • 2 g							

PT5MA

Industrial Grade • 0...5, 0...10 Vdc

Measuring Cable:

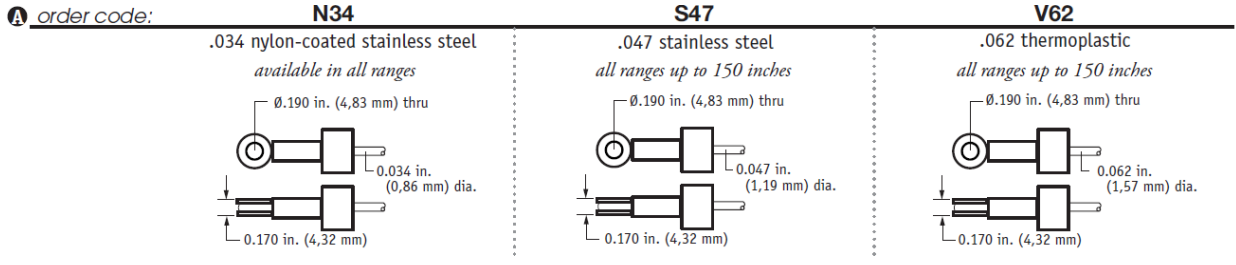

Cable Exit:

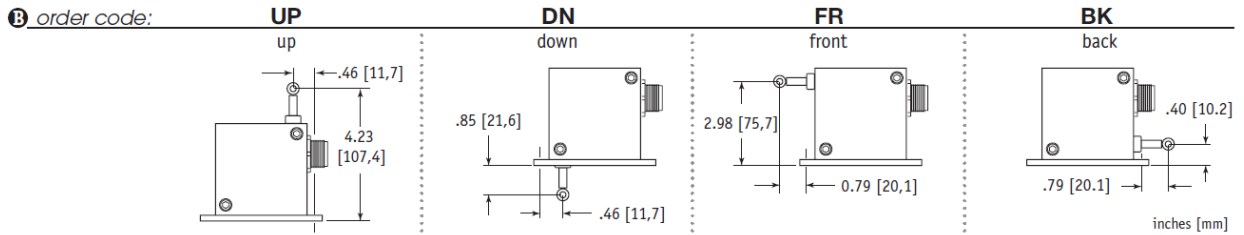

Output Signals:

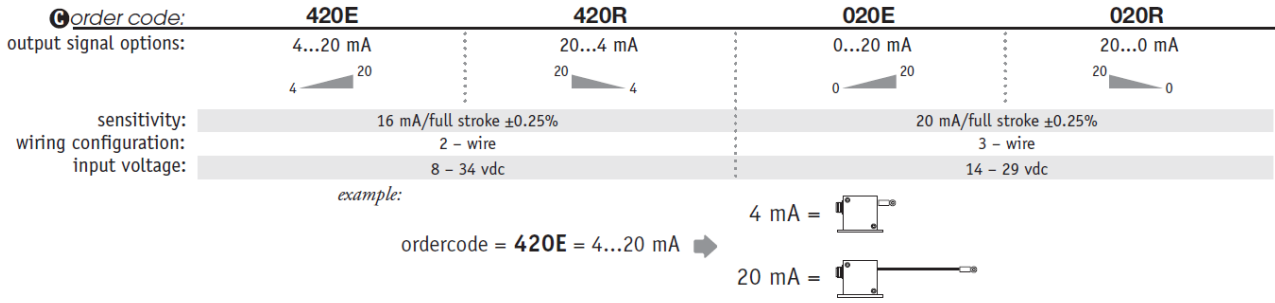

Electrical Connection:

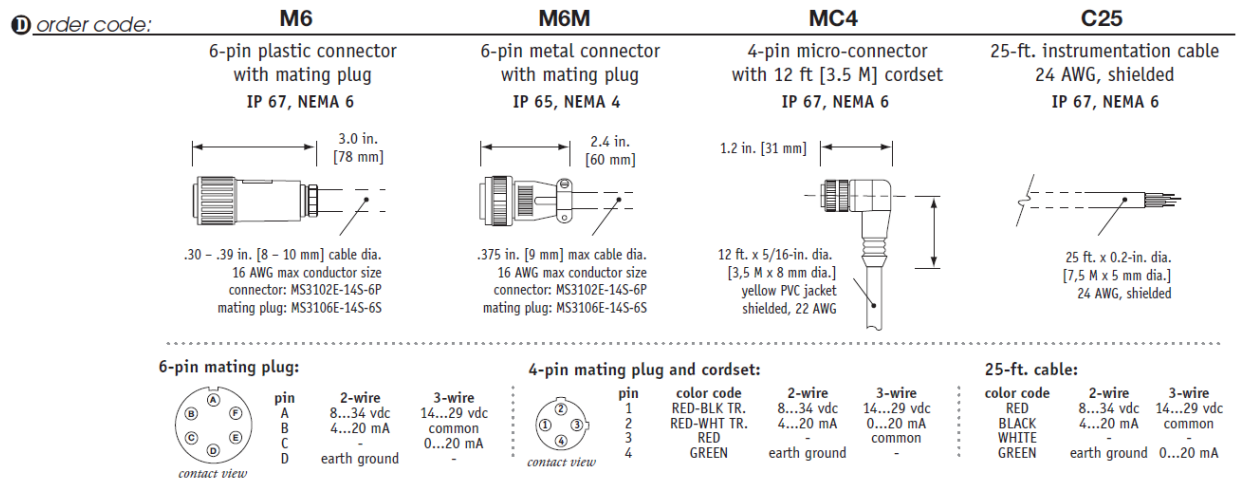

Output Signal Selection:

The output signal direction can be reversed at any time by simply changing the dip-switch settings found on the internal signal board. After the settings have been changed, adjustment of the Zero and Span trimpots will be required to precisely match signal values to the beginning and end points of the stroke.

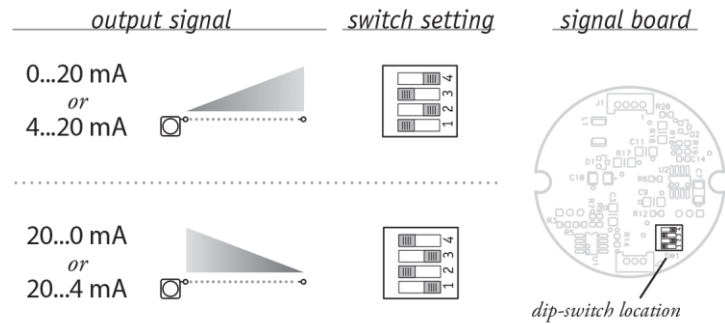

To gain access to the signal board, remove four Allen-Head Screws and remove end cover bracket.

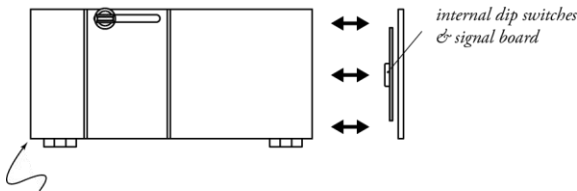

Caution! Do Not Remove Spring-Side End Cover
 Removing spring-side end cover could cause spring to become unseated and permanently damaged.

TE.com/sensorsolutions

Measurement Specialties, Inc., a TE Connectivity company.

Measurement Specialties, TE Connectivity, TE Connectivity (logo) and EVERY CONNECTION COUNTS are trademarks. All other logos, products and/or company names referred to herein might be trademarks of their respective owners.

The information given herein, including drawings, illustrations and schematics which are intended for illustration purposes only, is believed to be reliable. However, TE Connectivity makes no warranties as to its accuracy or completeness and disclaims any liability in connection with its use. TE Connectivity's obligations shall only be as set forth in TE Connectivity's Standard Terms and Conditions of Sale for this product and in no case will TE Connectivity be liable for any incidental, indirect or consequential damages arising out of the sale, resale, use or misuse of the product. Users of TE Connectivity products should make their own evaluation to determine the suitability of each such product for the specific application.

© 2015 TE Connectivity Ltd. family of companies All Rights Reserved.

PT5MA 12/01/2015