

Intrinsically Safe 4-20 mA Vibration Transmitters *VT Series*



Approvals: • CSA Approved • FM Approved
Div. 2, Groups A-D, N.I. Class I

Specifications

Maximum Load Resistance: 600 Ohms
Humidity Range: 0-95% Relative, Non-Condensing
Connectors: Positive Force Terminal Block Contacts
Max Frequency Response: 2 Hz to 20,000 Hz ±5%
Power: 24 to 32 VDC Unregulated/100 mA Nominal.
 This powers the accelerometer through the transmitter.
Isolation: 1000 VDC Minimum
Ambient Temperature: -40 C to +80 C
Weight: 6.4 Ounces

How To Order - Select the desired parameters using the selection guide.

Example Note: For other options, please contact CTC.

CTC Part Number: VT - 4 -

Accelerometer Input Type

- 050 50 mV/g
- 100 100 mV/g
- 500 500 mV/g

Output Mode - Vibration

- 2 ips, pk
- 5 ips, rms
- 6 mm/s, pk
- 7 mm/s, rms

Full Scale Vibration Range - Output Mode

- | | | | |
|-------|--------|--------|---------|
| 1 0-1 | 3 0-5 | 5 0-20 | 7 0-100 |
| 2 0-2 | 4 0-10 | 6 0-50 | |

Filters - High Pass

- 0 5 Hz
- 2 10 Hz
- 3 20 Hz
- 4 50 Hz
- 5 100 Hz
- 6 200 Hz
- 7 500 Hz
- 8 1000 Hz
- 9 2 Hz

Low Pass

- 0 None
- 1 50 Hz
- 2 70 Hz
- 3 100 Hz
- 4 200 Hz
- 5 500 Hz
- 6 1000 Hz
- 7 2000 Hz
- 8 5000 Hz

Vibration Transmitters. For certain critical or unattended machinery, the standard periodic machine condition monitoring program will not identify any transient faults that happen in between the monitoring cycle. Continuous monitoring may be needed in order to identify these transient faults to ensure the equipment will continue to perform as needed. The early fault identification can then allow time for a corrective action to be developed and implemented at a schedule downtime, rather than having to disrupt operations for a failure.

The CTC vibration transmitter accepts the vibration signal from an accelerometer and converts it to a 4-20 mA proportional output to the overall vibration (either in Peak or RMS - customer specified). Band pass filters can be specified to narrow the desired frequency range in order to focus on specific faults, if desired. The output can interface with a PLC or DCS system, which in turn can continuously monitor the health of the machine. This allows for alarming and trending of the machine condition. Some systems can even be programmed to shutdown of the equipment (either manually by an operator or through the PLC or DCS).

Although this output is proportional to the overall vibration limit of the machine in the frequency range specified, the analog signal from the accelerometer can also be accessed through the BNC connector or a terminal strip on the vibration transmitter. This option allows the analyst to perform diagnostic analysis on the machine fault as well as providing the continuous, overall monitoring and periodic, diagnostic monitoring.

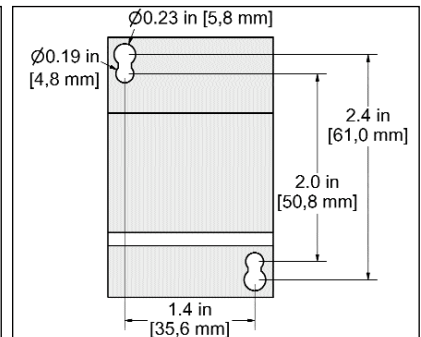
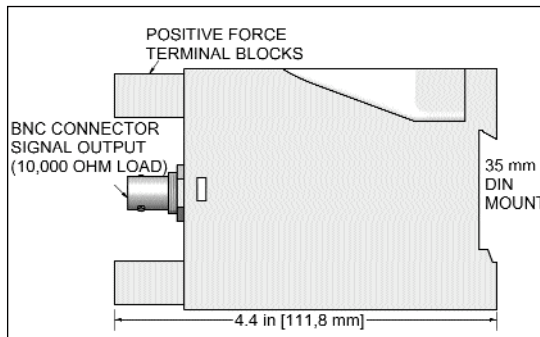
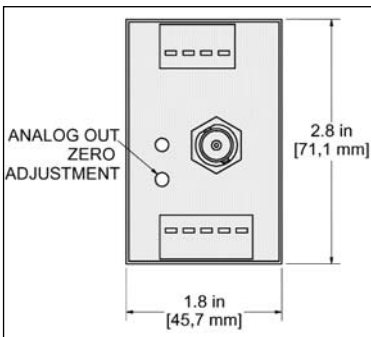

NOTES: • Non-Incendive (FM3611), Class 1, Div 2, GRPS B,C,D • Non-Incendive qualification does not require use of barriers • Install per ISA RP12.6 • Safe location apparatus must not use or generate in excess of 250 V

