

AC240 Series

Premium Series mini-MIL Accelerometer High Frequency
Top Exit Connector/Cable 100 mV/g

SECTION 1 - VIBRATION SENSORS
Accelerometers



Actual Product Size Shown



mini-MIL Must Use J2X Series Connectors

Product Features

High Performance Sensor for Demanding Applications

High Resonant Frequency with Excellent Frequency Response

- ± 50 g, Peak Dynamic Range
- 34 kHz Resonant Frequency
- $\pm 5\%$ Sensitivity

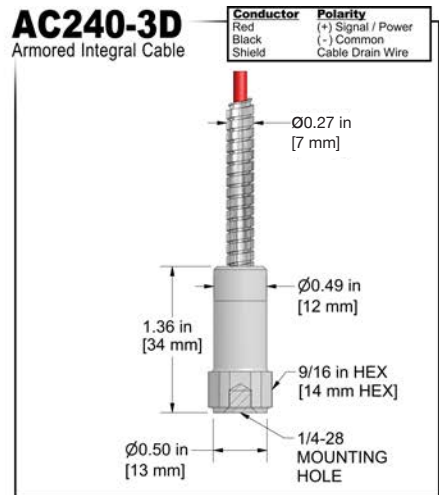
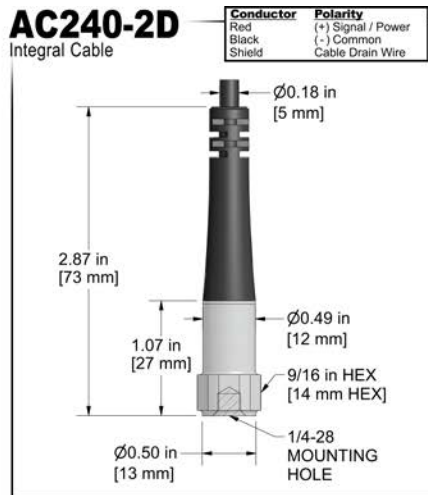
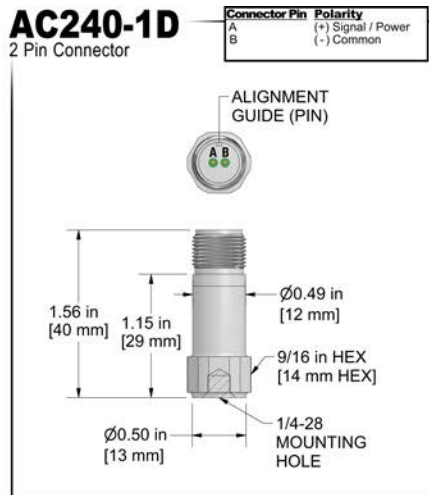

Specifications	Standard	Metric
Part Number	AC240	M/AC240
Sensitivity ($\pm 5\%$)	100 mV/g	
Frequency Response (± 3 dB)	36-1,500,000 CPM	0.6-25000Hz
Frequency Response ($\pm 10\%$)	60-720,000 CPM	1,0-12000 Hz
Frequency Response ($\pm 5\%$)	120-480,000 CPM	2-8000 Hz
Dynamic Range	± 50 g, peak	
Electrical		
Settling Time	<2.5 Seconds	
Voltage Source (IEPE)	18-30 VDC	
Constant Current Excitation	2-10 mA	
Spectral Noise @ 10 Hz	30 μ g/√Hz	
Spectral Noise @ 100 Hz	4 μ g/√Hz	
Spectral Noise @ 1000 Hz	2 μ g/√Hz	
Output Impedance	<100 ohm	
Bias Output Voltage	10-14 VDC	
Case Isolation	>10 ⁸ ohm	

Specifications	Standard	Metric
Environmental		
Temperature Range	-58 to 250°F	-50 to 121°C
Maximum Shock Protection	5,000 g, peak	
Electromagnetic Sensitivity	CE	
Sealing	IP68	
Submersible Depth (AC240-2D/3D)	200 ft.	60 m
Physical		
Sensing Element	PZT Ceramic	
Sensing Structure	Shear Mode	
Weight	0.7 oz	20 grams
Case Material	316L Stainless Steel	
Mounting	1/4-28	
Connector (non-integral)	2 Pin mini-MIL	
Resonant Frequency	2,040,000 CPM	34000 Hz
Mounting Torque	2 to 5 ft. lbs.	2,7 to 6,8 Nm
Mounting Hardware	1/4-28 Stud	M6x1 Adapter Stud
Calibration Certificate	CA10	

Ordering Information

Standard	AC240-1D (1/4-28 Stud)	AC240-2D - / (1/4-28 Stud)	AC240-3D - / (1/4-28 Stud)
		(length in feet) (termination)	(maximum armor length 100 ft.) (cable length in feet) (termination)
Metric	M/AC240-1D (M6x1 Adapter Stud)	M/AC240-2D - / (M6x1 Adapter Stud)	M/AC240-3D - / (M6x1 Adapter Stud)
		(length in meters) (termination)	(maximum armor length 30 m) (cable length in meters) (termination)

INTERTECHNOLOGY
INC.

19 Waterman Ave, Toronto, Ont. M4B1Y2
Ph#416-445-5500 Fax#416-445-1170
Toll Free: 1-800-465-1600
Email: sales@intertechnology.com
Website: www.intertechnology.com

Cable Termination Options: E F L Z



VIBRATION ANALYSIS HARDWARE

Backed by our Unconditional Lifetime Warranty