

AC220 Series

High Frequency mini-MIL Accelerometer, Top Exit Connector/Cable, 10 mV/g

SECTION 1 - VIBRATION SENSORS
Accelerometers

mini-MIL Must Use J2X Series Connectors

Product Features

Very High g Side Exit Accelerometer for High Frequency Applications
Helps to Detect Gearbox Defects and Other High Frequency Faults

- 1,0 - 25000 Hz (60 - 1,500,000 CPM) Frequency Response
- 10 mV/g, $\pm 5\%$ Sensitivity
- 34 kHz Resonant Frequency

Actual Product Size Shown

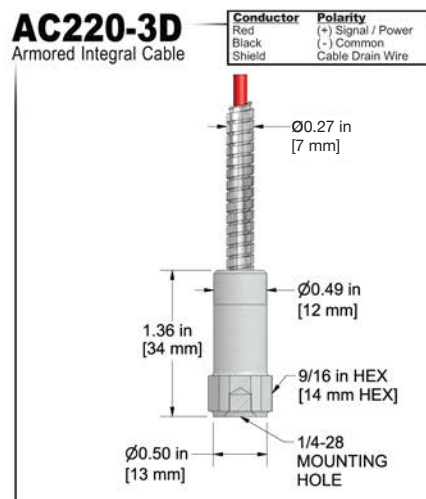
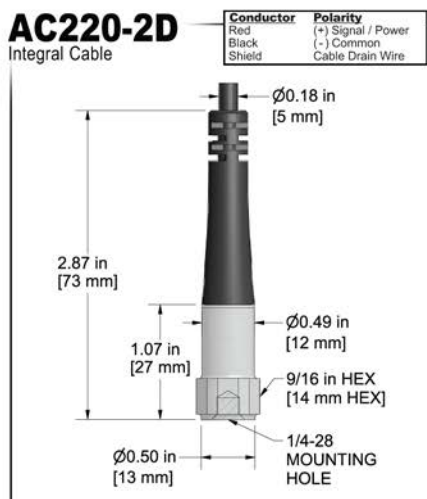
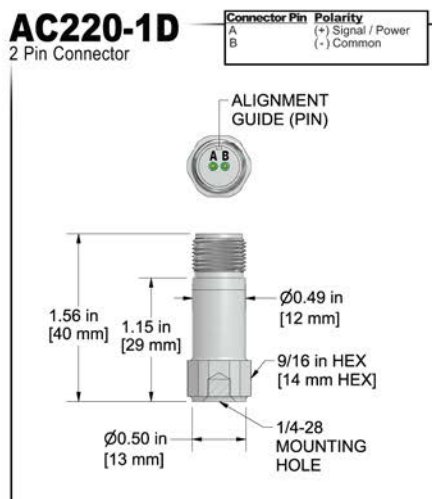

Specifications	Standard	Metric
Part Number	AC220	M/AC220
Sensitivity ($\pm 5\%$)	10 mV/g	
Frequency Response ($\pm 3\text{dB}$)	60-1,500,000 CPM	1,0-25000 Hz
Frequency Response ($\pm 10\%$)	90-420,000 CPM	1,5-7000 Hz
Frequency Response ($\pm 5\%$)	180-180,000 CPM	3,0-3000 Hz
Dynamic Range	± 500 g, peak	
Electrical		
Settling Time	<2 Seconds	
Voltage Source (IEPE)	18-30 VDC	
Constant Current Excitation	2-10 mA	
Spectral Noise @ 10 Hz	100 $\mu\text{g}/\sqrt{\text{Hz}}$	
Spectral Noise @ 100 Hz	19 $\mu\text{g}/\sqrt{\text{Hz}}$	
Spectral Noise @ 1000 Hz	5 $\mu\text{g}/\sqrt{\text{Hz}}$	
Output Impedance	<100 ohm	
Bias Output Voltage	10-14 VDC	
Case Isolation	>10 ⁸ ohm	

Specifications	Standard	Metric
Environmental		
Temperature Range	-58 to 250°F	-50 to 121°C
Maximum Shock Protection	5,000 g, peak	
Electromagnetic Sensitivity	CE	
Sealing	IP68	
Submersible Depth (AC220-2D/3D)	200 ft.	60 m
Physical		
Sensing Element	PZT Ceramic	
Sensing Structure	Shear Mode	
Weight	0.7 oz	20 grams
Case Material	316L Stainless Steel	
Mounting	1/4-28	
Connector (non-integral)	2 Pin mini-MIL	
Resonant Frequency	2,040,000 CPM	34000 Hz
Mounting Torque	2 to 5 ft. lbs.	2,7 to 6,8 Nm
Mounting Hardware	1/4-28 Stud	M6x1 Adapter Stud
Calibration Certificate	CA10	

Ordering Information

Standard	AC220-1D (1/4-28 Stud)	AC220-2D - / (1/4-28 Stud)	AC220-3D - / (1/4-28 Stud)
		(length in feet) (termination)	(maximum armor length 100 ft.) (cable length in feet) (termination)
Metric	M/AC220-1D (M6x1 Adapter Stud)	M/AC220-2D - / (M6x1 Adapter Stud)	M/AC220-3D - / (M6x1 Adapter Stud)
		(length in meters) (termination)	(maximum armor length 30 m) (cable length in meters) (termination)

INTERTECHNOLOGY
INC.

19 Waterman Ave, Toronto, Ont. M4B1Y2
Ph#416-445-5500 Fax#416-445-1170
Toll Free: 1-800-465-1600
Email: sales@intertechnology.com
Website: www.intertechnology.com

Cable Termination Options: E F L Z



VIBRATION ANALYSIS HARDWARE

Backed by our Unconditional Lifetime Warranty