

## Model A2 Heavy Industrial Pressure Transmitter



LOOK FOR THIS MARK ON OUR PRODUCTS

### APPLICATIONS:

*Test stands, compressor control, hydraulic systems, process automation, pump and pneumatic systems control*

### FEATURES:

- Pressure ranges from 5 psi through 10,000 psi
- CE mark
- 316L SS wetted materials
- 304 SS case
- Six output signals to choose from
- Optional absolute pressure ranges available
- Optional external zero and span potentiometers

The Ashcroft® A2 pressure transmitter is ideal for a broad spectrum of pressure sensing requirements found in heavy industrial, and test and measurement applications. It offers the instrument specifier a wide choice of construction and performance variables.

The Ashcroft® A2 is designed and manufactured to provide the user with accurate, reliable, and stable output data. This is accomplished through the use of an on board microprocessor, that is programmed during a unique digital compensation process, to provide extremely linear and precise performance over the entire specified pressure and temperature range .

### PERFORMANCE SPECIFICATIONS

Reference temperature 70°F (21°C)

**Accuracy, Three Classes (% Span):** ±.25 ±0.5 ±1.0  
Includes non-linearity (Terminal Point Method), hysteresis, non-repeatability, zero offset and span setting errors  
Best Fit Straight Line\* (BFSL): ±.20 ±.40 ±.50

Includes non-linearity hysteresis, non-repeatability errors

\*Add ±.05% for ranges above 5000 psi

#### Stability:

≤ ±0.25% Span/year @ reference conditions

**Durability:** Greater than 10 million cycles

### ENVIRONMENTAL SPECIFICATIONS

#### Temperature Limits:

Storage: -40 to +125°C (-40 to 257°F)  
Process: -40 to +125°C (-40 to 257°F)  
Operating: -40 to +125°C (-40 to 257°F)  
Compensated\*: -20 to +85°C (-4 to 185°F)  
\*Consult factory for other options

**Temperature Effects:** -20 to +85°C (-4 to 185°F)

• 1.0% of Span for .25% Accuracy Class

• 2.0% of Span for .50% and 1.0% Accuracy Classes

**Humidity Effects:** No performance effects from

0 to 95% relative humidity, non-condensing, 0-100% RH with "W" enclosure.

\*Consult factory

### FUNCTIONAL SPECIFICATIONS

**Response Time:** <2ms

**Pressure Ranges:** Vacuum, gauge, compound and absolute pressure from 0-5 psi through 0-10,000. Equivalent ranges in bar available. See order guide section (reverse.)

#### Vibration Effect:

Shock: 100g Peak, 11ms  
Random: 10g RMS, 20-2000Hz  
Sweep: 50-2000Hz, 5g peak

**Position Effect:** ± 0.02% Typical

**CE Mark (standard):** EN 61326:1997 + A1: 1998 Annex A

Heavy Industrial Immunity (Annex A, Table A.1)

Light Industrial/Residential Emission (Table 4)

**Overpressure (F.S.):\*** **Proof** **Burst**

0#/vac. to 300 psi 1.5 x F.S. min. 2 x F.S.

500-10,000 psi 1.2 x F.S. 1.5 x F.S.

\*For higher overpressure ratings use XK8 option.

See page 2 for additional option.

### ELECTRICAL SPECIFICATIONS

**Output Signal:** **Supply Voltage: (unregulated)**

		Minimum	Maximum
0-5Vdc	(3 Wire)	12Vdc	36Vdc
0-10Vdc	(3 Wire)	14Vdc	36Vdc
1-5Vdc	(3 Wire)	10Vdc	36Vdc
1-6Vdc	(3 Wire)	10Vdc	36Vdc
4-20mA	(2 Wire)	12Vdc	36Vdc

#### Power Requirements:

Supply Current: <5mA for voltage outputs

**Electrical Terminations:** See To Order section (reverse) for options

**Circuit Protection:** Reverse polarity and mis-wire protected  
**Insulation Resistance (Circuit to Case):** 100Mohm @ 30Vdc

### PHYSICAL SPECIFICATIONS

**Case:** Material 304SS

**Wetted Materials:** 316L SS diaphragm and pressure port, optional 17-4PH SS diaphragm and 316L SS pressure port (see How to Order Section).

#### Ingress Protection Rating:

Enclosure	Code	Rating
Basic	(S)	IP65, NEMA 4X
Zero/Span	(Z)	IP65, NEMA 4X
All Welded (w/Z/S)	(Y)	IP65, NEMA 4X
All Welded (w/o Z/S)	(W)	IP67, NEMA 6

All units less than 500 psi include a small metal sintered filter at the top of the unit. This is necessary to equalize the internal pressure with atmospheric pressure but can be a point of moisture ingress.

#### NOTE:

Refer to Ashcroft Model A2X for Explosion / Flame Proof configurations and Ashcroft Model A4 for Intrinsically Safe/Non-Incendive applications.

# Model A2 Heavy Industrial Pressure Transmitter

## DIMENSIONS dimensions in ( ) are mm

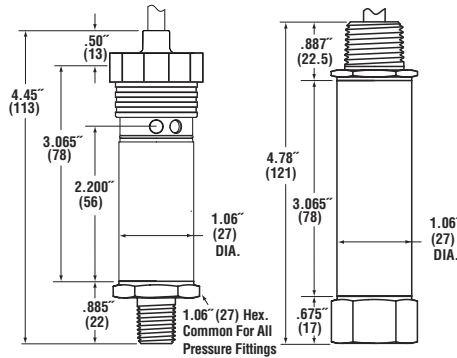

HEAVY INDUSTRIAL (ENCLOSURE S, Z, Y, W)

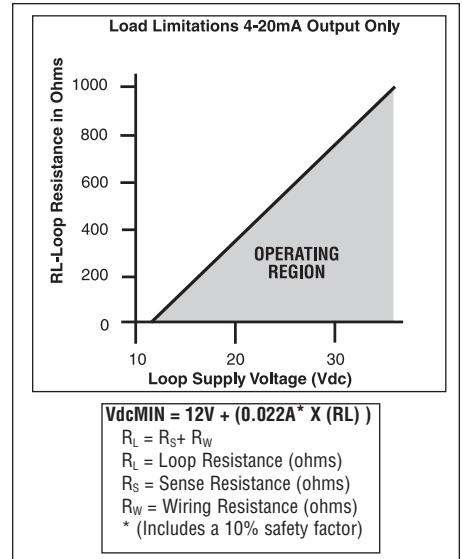

### XX8 OVERPRESSURE (F.S.)

	Proof	Burst
0 to 2000 psi	200%	800%
3000 to 5000 psi	150%	300%
7500 to 10,000 psi	120%	150%

### NOTE:

Refer to Ashcroft Model A2X for Explosion / Flame Proof configurations and Ashcroft Model A4 for Intrinsically Safe /Non-Incendive applications.

### How To Order

<b>A</b> <b>2</b>									<b>X</b>
<b>Type Configuration</b> (A2)	<b>Accuracy / Temp. Effects</b> (A) 0.25% ≤ 1.0% (-20°C to +85°C) (B) 0.50% ≤ 2.0% (-20°C to +85°C) (C) 1.00% ≤ 2.0% (-20°C to +85°C)		<b>Output Signal</b> (05) 0-5 Vdc (10) 0-10 Vdc (15) 1-5 Vdc (16) 1-6 Vdc (42) 4-20mA	<b>Electrical Termination</b> <b>Integral Cable (Pigtails)</b> (F2) 3' shielded cable <sup>(1)</sup> (P1) (specify length) <sup>(1)</sup> <b>Hirschmann Style Form A DIN 43650-A</b> (DN) w/o mating conn. <sup>(1)</sup> (D0) with mate, no cable <sup>(1)</sup> (D2) with mate, 3' cable <sup>(1)</sup> (D1) with mate, (specify length) <sup>(1)</sup> <b>4-Pin Bendix Style</b> (B4) w/o mating conn. <sup>(2)</sup> (H1) with mate, no cable <sup>(2)</sup> (L1) with mate, 3' cable <sup>(2)</sup> (P2) with mate, (specify length) <sup>(2)</sup> <b>½ NPT-M Conduit Shielded Cable</b> (C1) 3' shielded cable <sup>(3)</sup> (C6) 15' shielded cable <sup>(3)</sup> (C7) 30' shielded cable (P7) shielded cable (specify length) <b>½ NPT-M Conduit Flying Leads</b> (C2) 3' flying leads <sup>(3)</sup> (C5) 10' flying leads <sup>(3)</sup> <b>M12 Threaded</b> (EW) w/o mating conn. <sup>(1)</sup> (E0) with mate, no cable <sup>(1)</sup> (E2) with mate, 3' cable <sup>(1)</sup> (E1) with mate, (specify length) <sup>(1)</sup>	<b>Pressure Range</b> (1.5#) 1.5 psi <sup>(5),(6),(7)</sup> (5#) 5 psi <sup>(5),(6)</sup> (10#) 10 psi <sup>(5),(6)</sup> (15#) 15 psi <sup>(5)</sup> (30#) 30 psi <sup>(5)</sup> (50#) 50 psi (60#) 60 psi (75#) 75 psi (100#) 100 psi (150#) 150 psi (200#) 200 psi (300#) 300 psi (500#) 500 psi	<b>Pressure Range</b> (750#) 750 psi (1000#) 1000 psi (1500#) 1500 psi (2000#) 2000 psi (3000#) 3000 psi (5000#) 5000 psi (7500#) 7500 psi (10,000#) 10,000 psi <sup>(4)</sup> (0# & vac.) 0 psi/vac. <sup>(5),(6)</sup> (15# & vac.) Vac./15 psi <sup>(5),(6)</sup> (30# & vac.) Vac./30 psi <sup>(5),(6)</sup> (45# & vac.) Vac./45 psi <sup>(6)</sup> (60# & vac.) Vac./60 psi <sup>(6)</sup>	<b>Measurement Type</b> (G) Gauge Pressure Sensor (A) Absolute Pressure Sensor	<b>Optional X-Variations (XCL)</b> Non-standard <sup>(7)</sup> calibration <b>(XK8)</b> 17-4PH SS Sensor Material <b>(X6B)</b> Cleaned For Oxygen Service	
<b>Enclosure</b> (S) Basic (Z) Zero & Span Access (Y) Welded with Zero & Span Access (W) Welded w/out Zero & Span Access  (See electrical termination coding for available selections)	<b>Pressure Connection</b> (M01) ½ NPT-M (M02) ¼ NPT-M (F02) ¼ NPT-F (MEK) 7/16-20 SAE-M (F09) 3/16-18 (¼)-F (Aminco) (M04) ½ NPT-M (F04) ½ NPT-F  (MG4) G ½ M (VM2) VCR inlet fitting ¼" VCR gland with 3/16-18 male nut (VF2) VCR inlet fitting ¼" VCR gland with 3/16-18 female nut  (others available upon request)								
<b>NOTE:</b> All A2 pressure transmitters include a 9 pt. NIST traceable calibration certificate									

<sup>(1)</sup> Available with enclosure code (S, Z)  
<sup>(2)</sup> Available with enclosure code (S, Z, W)  
<sup>(3)</sup> Available with enclosure code (W, Y)  
<sup>(4)</sup> 17-4PH SS Sensor Required  
<sup>(5)</sup> 17-4PH SS Sensor Not Available  
<sup>(6)</sup> Gauge pressure only  
<sup>(7)</sup> Available only with accuracy B & C